



## Automation Solutions for Packaging Plants

We automate your success.

# Packaging Processes from Production to Delivery



Efficient and flexible packaging of products significantly contributes to corporate success in numerous lines of business. The efficiency of packaging machines, in turn, depends on their ability to quickly and easily meet new requirements.

The packaging machines used most are film packaging machines, as in many businesses a great variety of products is packed this way. For both packaging engineers and machine builders, this variety holds enormous technical challenges aiming at extremely high-precision production plants of maximum efficiency, tailor-made to the requirements of the respective customers.

Integrated automation concepts allow for both modular and stand-alone packaging machines to be equipped with perfectly synchronized central and remote automation components.

# Automating Diversity



The Motion Control automation systems by Jetter AG enable controlling and monitoring the complete process chain whether of individual packaging machines or of entire packaging lines.

Implementing various technological functions and processes such as filling, forming, sealing, collecting, and palletizing always results in best orchestrated and scalable automation systems for optimum performance of the packaging line.

The following packaging applications benefit partially or as a whole from the highly performant automation concepts by Jetter AG:

- Horizontal form-fill-seal machines (HFFS)
- Vertical form-fill-seal machines (VFFS)
- Thermoform, fill and seal machines (TFFS)
- Cartoning machines
- Labeling systems

# Horizontal form-fill-seal machine (HFFS)

The high-speed allrounder of film packaging



HFFS are apt for packaging dimensionally stable products which allow for synchronization of position and stroke via gripper chain or flat belt. A core aspect of film packaging is film tension. The film feeding unit consist of combined lane-infeed and longitudinal sealing rollers which also control the lengths of different kinds of packaging.

If printed film is to be used, the printed pattern on the film must be synchronized with the position of the product by means of print-mark control. The film tube created in the forming tool wraps the positioned product. Longitudinal hot sealing is thermo-regulated.

Cross-sealing which is also thermo-regulated, as well as cross-cutting are rotatory or in concurrent mode (Box Motion), depending on the electronic cam discs and drives applied. Print-mark control causes cross-sealing and cut-off of the package to be reproducibly placed at the correct position.

Primary-packed products are synchronized with a flat belt for separation and discharge. Parameter changes "on the fly" must be enabled in FFS machines, in order to increase the flexibility of the respective system. Master-slave drive solutions are best apt for this.

# The Jetter solution

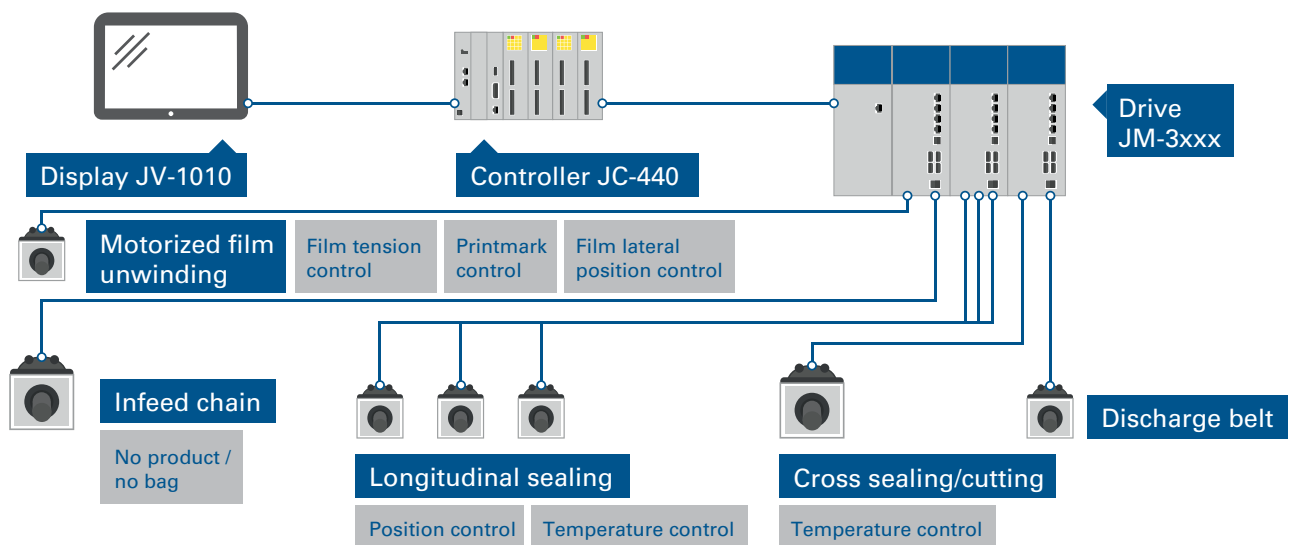

## Winding perfection

- Significant reduction of drive and controller programming thanks to direct connection of I/Os and axes with only one programming language being applied
- No-product-no-bag feature supported by coupling and decoupling of axes or axis groups
- Increased product quality at decreased cycle times by means of
  - electronically tension controlled and/or torque-based film handling
  - slip compensation by length measuring directly on the film
  - print mark control for high-precision correction of positions
  - speed-dependent thermal regulation of the sealing units
  - "on the fly" dynamically adjustable electronic cam disks, e.g. in the cross-sealing unit
- Multi-axis servo amplifiers by Jetter enable integration of all functions in the most confined of spaces this way saving control cabinet resources
- Personalized HMI surface areas

# Vertical form-fill-seal machine (VFFS)

Safe packaging for liquid and solid stuff



VFFS machines are apt for bagging all free-flowing powdery products as well as liquid substances. Extremely versatile automation systems - both classical PLC solutions and computation-bound multi-axis tasks (Motion Control) - are applied in this case.

The film is unwound from a reel and fed into the machine through a feeding unit. The film is advanced via vertically positioned discharge conveyor or grippers in linear direction. If printed film is to be used, the printed pattern on the film must be synchronized with the completed bag by means of print-mark control.

To the bag formed by the folding box and the forming tube, thermo-regulated cross-sealing, as well as cross-cutting is applied. The product is filled into the open bags through the forming tube.

Then, the film is unwound by one bag's length. Then the size of the bag is determined by the intermittent or synchronously running cross-sealing and cross-cutting unit. Various peripherals such as bunker conveyors, multi-head weighers, volumetric and gravimetric dosing systems and labeling systems can be implemented using flexible automation solutions.

# The Jetter solution

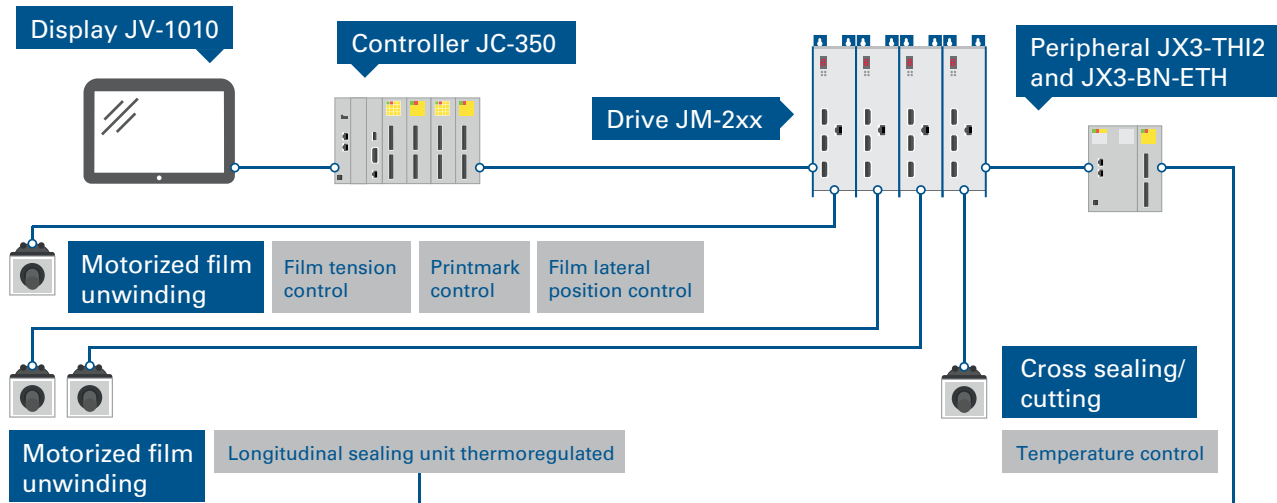

## Filling perfection

- Cost-saving by reducing control components and by direct connectivity of multi-head weighers or dosing devices
- The film is precisely unwound by simply synchronizing the drives with electronic gearing
- The bags are precisely sealed and separated by dynamically coupling axes or axis groups in and out ("Flying shear")
- In case of increased pulse rates, product quality is improved by print-mark recognition for highly precise correction of positions
- The bag length is corrected "on the fly"



# Thermoform, fill and seal machine (TFFS)

Independent when it comes to film packaging



One production line can comprise tray manufacturing, product infeed, gas flushing (MAP) and sealing. Thus, thermoforming machines are mainly used in food processing industry for packaging fresh produce.

The film is gained from thermoformable and sealable plastic and is formed in a chamber by positive or negative pressure. The forming tool is drive-controlled via electronic cam disc. Electronic film tension control and powerful servo motors in this case grant exact advance strokes as well as the required tension of the film. Chunky and/or liquid media can be taken to the trays in semi- or fully-automated mode. To execute this process, pick&place, portal and servo-dosing features are most useful.

After forming and filling the trays, they are thermo-sealed in intermittent mode by a top film. The position of the printed sealing film is controlled by print-mark recognition. At the end of the production chain, the individual packages are cut, the residual film is wound up and separated. The machines can produce one packing set or several ones. Devices for MAP gas flushing such as vacuum pumps, gas nozzles and gas analyzers which are there to evacuate ambient air and flush the package with protective gas before sealing them are also applied. The information needed is transmitted and managed in the BDE/MDE system via SCADA functions.



# The Jetter solution

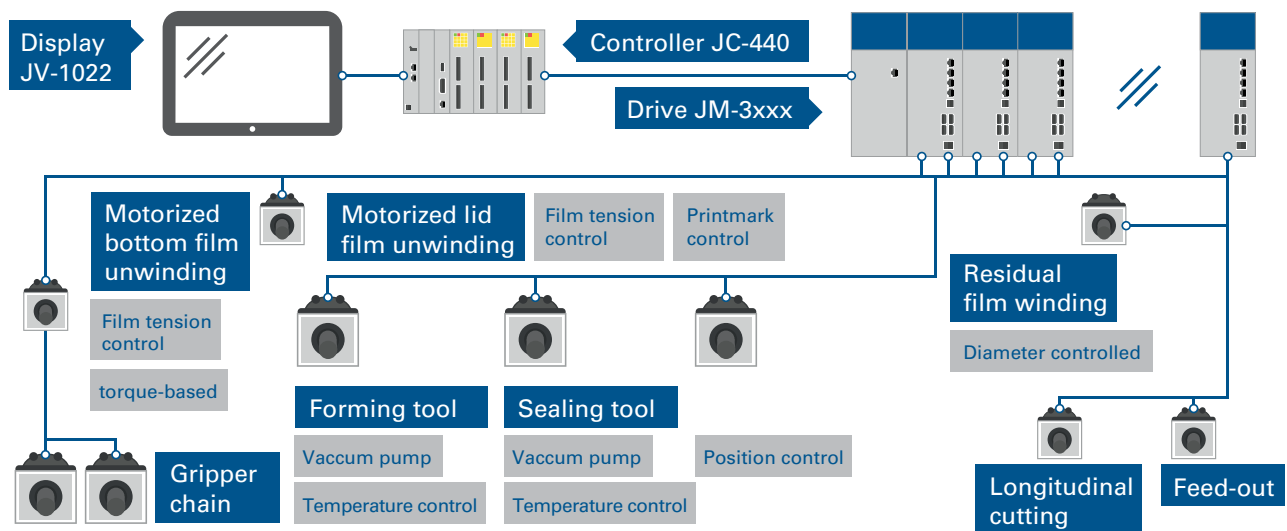

## Servo-controlled and very smooth

- Exact tension of top and bottom film thanks to electronic tension control and/or torque control
- Contamination of side seals is prevented By means of jerk control in the film advance, the Motion Control feature "non-splash-over" helps to prevent the product from spilling over while launching and accelerating the machine
- Increased product quality at increased pulse rates thanks to
  - high tractive force at the gripper chain by state-of-the-art Motion Control systems, such as electric cam discs
  - thermo-regulation of the forming and sealing units depending on velocity
  - all functions being controlled via touch screen. The user interface can be designed individually by JetViewSoft
- Product infeed systems and peripherals can be easily integrated into the automated process via bus node
- Simple connectivity of the sensor and measuring systems when gas flushing is applied (MAP functions)
- Product tracking by SCADA database and process connectivity

# Horizontal folding-box cartoning machine

Packaging processes featuring a great number of variants



Cartoning machines package the goods in pre-manufactured folding boxes - the cardboard tubes. The machines operate either in intermittent or in continuous mode. They have been designed as either horizontal or vertical cartoners. Pharmaceuticals, cosmetics and food processing industry range highest among the fields of application. The cartons to be folded are taken from a tray to be separated and erected. The filling goods are then fed into the opened box, the upper and lower flaps of the box are either glued or tucked in and finally closed by means of switches.

In most cases, a cartoner is part of a packaging line. In connection with vertical form-fill-seal machines, transfer systems cause the horizontal cartoner to position the finished bags correctly on the infeed chain. The infeed chain transports the bags, which might have passed an equalizing station, to the product infeed station in the cartoner, where they are pushed into the folding boxes. Key features of all cartoners are precise carton and product infeed, as well as fast and simple format changeover.

# The Jetter solution

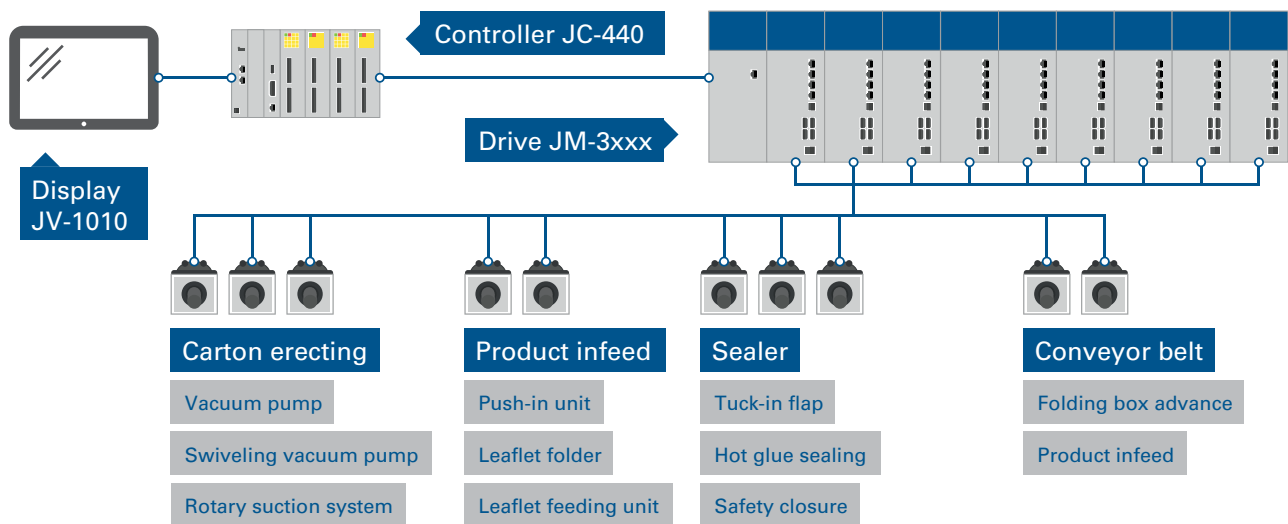

## Automation to get ready for dispatch

- Time and cost saving, as well as fast implementing of customers' requirements applying ONE system and ONE software
- Short setup times, flexible changeover between products by combining technological axis functions, Motion Control (MC), and path control (CNC)
- Consistent quality during continuous packaging processes by applying electronic cam disc and drive functions featuring high positioning accuracy
- Highly dynamic performance through professionally engineering the feeding systems and optimizing motions to render power-efficient, jerk-free motion sequences
- Simple connections of lines by various bus systems such as EtherCAT®, Ethernet TCI/IP, Profinet®, CANopen®, etc.
- Fit for Industry 4.0: evaluation and acquisition of all process data, availability and customization via ERP/PDA/MES systems

# Labeling

Flexibility meets accuracy



Round container shapes and special forms pose a great challenge to the automation of labeling machines. Here, circumferential labels adapted to the design and size are frequently affixed, which requires a special construction of the machine.

At the same time, retooling the system should be as quick as possible in order to be able to quickly realize the labeling of small and medium piece counts as well.

# The Jetter solution

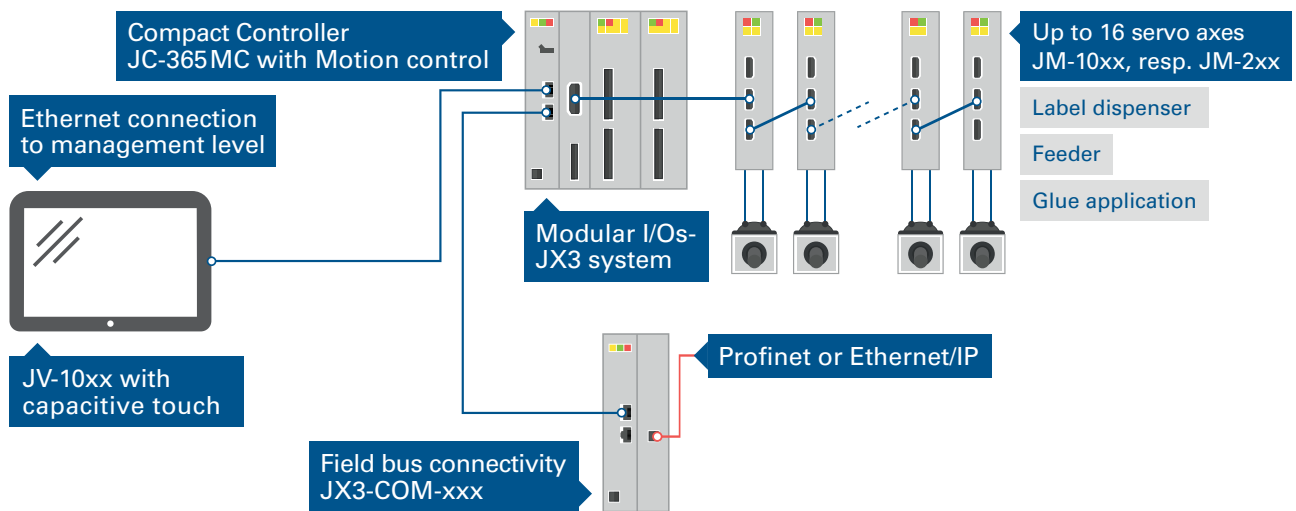

## Always fits | Fits right

- Correct positioning throughout by synchronization with the conveyor belt and by print-mark recognition
- Individual labeling functions by free combination of position offsets, triggers and print-marks
- Scalable in price and performance through flexible drive selection: Stepper motor, DC/AC motor or servo motor at identical programming

# The Jetter automation solutions for packaging machines – your advantages



Jetter AG is a member

## ■ Shorter cycle times

With our special solutions for packaging machines, you can further improve the cycle rates of your machines. They help you significantly boost productivity at consistently high process reliability.

## ■ Seamless systems integration

Seamless integration of control, drive and operating functions helps you conserve important resources even at the programming stage. You can also benefit from this during commissioning and reduce service costs.

## ■ Generating competitive edges

The demands that packaging lines are expected to meet are becoming ever higher. Machines are expected to be faster, more efficient and more economical at the same time. Our tool for calculating the ideal path will track down the perfect parameters. This keeps your filling system running in the optimum range - smoothly but nevertheless dynamically. Energy consumption and wear can therefore be reduced to a minimum.

## ■ Easy maintenance

Profit from the advantages of modern, sophisticated systems, also with regard to maintenance. No specialized programming skills are required. A screwdriver and a USB flash drive or SD card are all you need. Easy access via remote maintenance is possible.

## ■ Fit for Industry 4.0

Our systems with an end-to-end data flow enable economical production starting at batch sizes of 1 by

- integrating the controller, drives and operating function
- integrating data management in the control system
- connecting directly to ERP, PDA, MES
- simple company-wide networking

# The Jetter industry competence

## Our solutions for your systems

Jetter AG offers company-wide and scalable automation solutions for a great number of industries. Our specialist teams have extensive expertise in the specific production requirements actively take a share in technical further development. They pay special attention to continuously optimizing the processing operations.

Packaging



Filling



Assembly | Handling systems



Window manufacturing



Glass container industry



Agricultural technology



Municipal vehicles





## Jetter AG at a glance

For over 35 years, Jetter AG has developed, produced, and engineered both integrated and open automation solutions for various lines of business. These solutions comprise perfectly coordinated software and hardware components, which, whether being part of a system or cooperating with other components, contribute to a remarkable increase in efficiency. Consistently supporting both open and classic standards of Jetter AG products guarantees maximum flexibility at any time.

Jetter AG  
Graeterstrasse 2  
71642 Ludwigsburg | Germany

Phone +49 7141 2550-0  
Fax +49 7141 2550-425  
info@jetter.de  
www.jetter.de