

Jetter AG

Gräterstraße 2
D-71642 Ludwigsburg
Germany

Kontakte:

E-Mail - Vertrieb: sales@jetter.de
E-Mail - Hotline: hotline@jetter.de
Telefon - Hotline: +49(0)7141/2550-444

Installationsanleitung

Artikel-Nr.: 60880620 | Version 1.10

Juni 2018 / Printed in Germany

Laden Sie die Betriebsanleitung von www.jetter.de unter Downloads herunter.

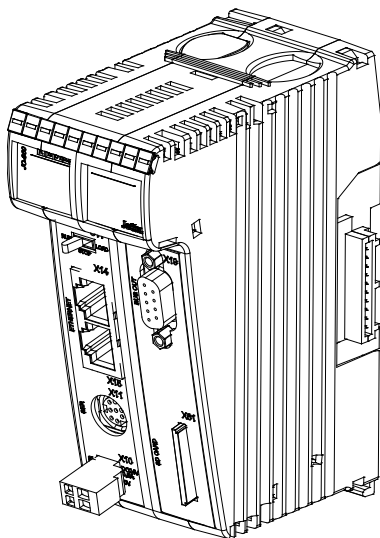

Lieferumfang

1 x	JC-365	Optionen: [MC]-[A]-[R]
1 x	60870409	2-poliger Stecker, Zugfederanschluss
10 x	60870411	Klemmenmarkierer
1 x	60880620	Installationsanleitung

Montage auf Hutschiene EN 50022

Schritt

Vorgehen

1

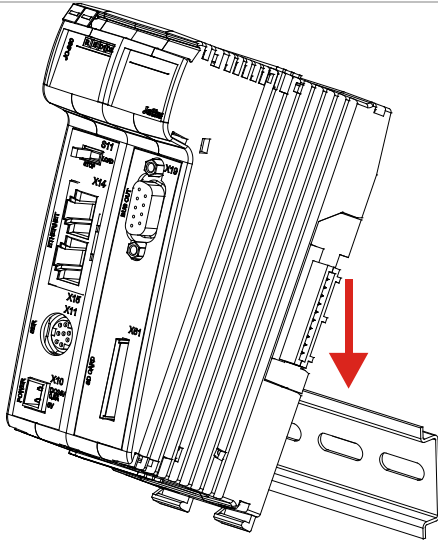

Setzen Sie die JC-365 auf die Hutschiene oben auf.

2

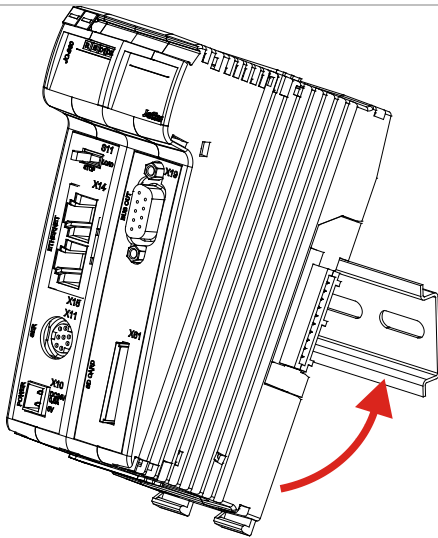

Bewegen Sie die JC-365 in Pfeilrichtung, bis sie auf der Hutschiene einrastet.

3

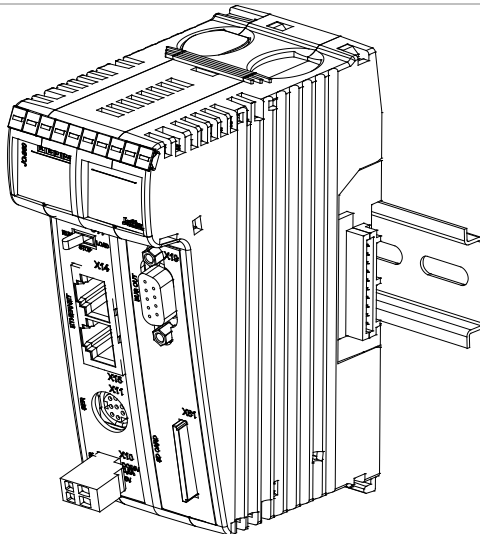

Die JC-365 sitzt nun fertig montiert auf der Hutschiene.

Einstellen der IP-Adresse

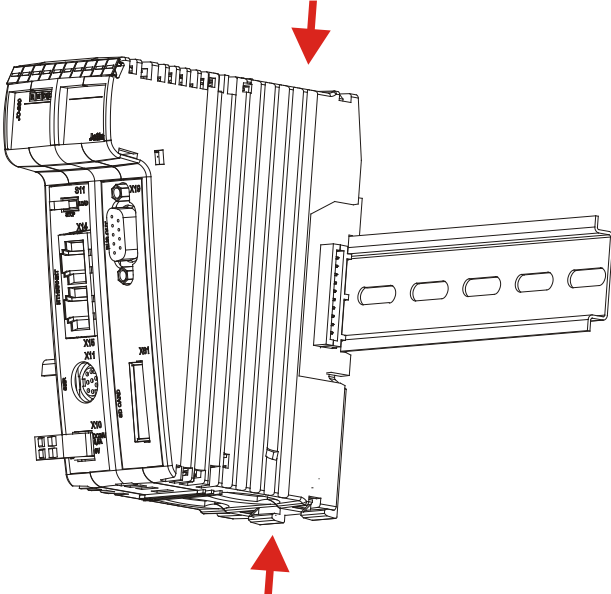
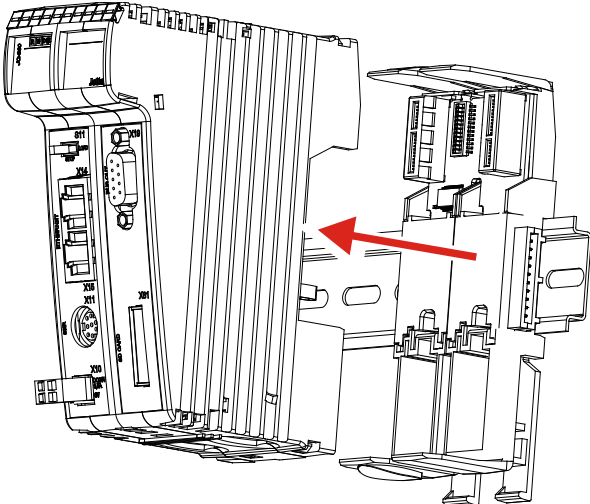
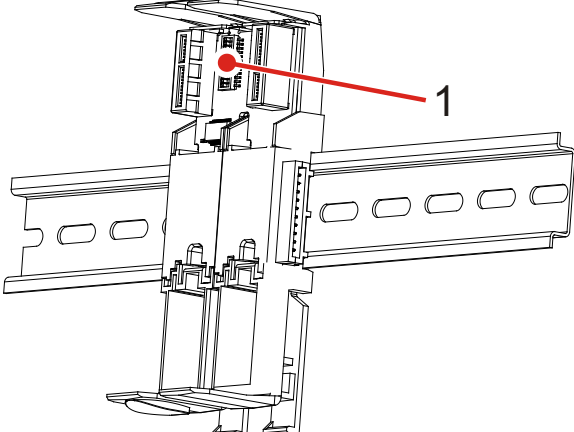
Schritt	Vorgehen
1	Schalten Sie die JC-365 und alle JX3-Module der JX3-Station spannungslos.
2	 <p>Drücken Sie auf die obere und untere Rastlasche.</p>
3	 <p>Ziehen Sie das JX3-Gehäuse nach vorne ab.</p>
4	 <p>Auf dem JX3-Backplane-Modul sind nun die DIP-Schalter (1) erreichbar.</p>

Einstellen der IP-Adresse

Schritt	Vorgehen
5	<p>Ändern Sie die IP-Adresse über die DIP-Schalter (1).</p> <div style="display: flex; justify-content: space-around; align-items: flex-start;"> <div style="text-align: center;"> <p>ON 1 2 3 4 5 6 7 8 9 10 11 12</p> </div> <div style="text-align: left;"> <p>IP-Adresse: 192.168.1.1 Auslieferungszustand</p> </div> </div> <div style="display: flex; justify-content: space-around; align-items: flex-start; margin-top: 10px;"> <div style="text-align: center;"> <p>ON 1 2 3 4 5 6 7 8 9 10 11 12</p> </div> <div style="text-align: left;"> <p>IP-Adresse: 192.168.10.15 Default IP-Adresse</p> </div> </div>
6	Setzen Sie das JX3-Gehäuse wieder auf das JX3-Backplane-Modul.
7	Versorgen Sie die JX3-Station wieder mit Spannung.





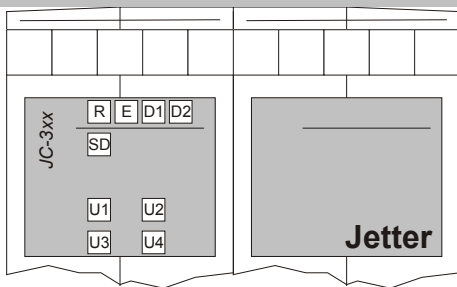



















Weitere Informationen zum Einstellen der IP-Adresse entnehmen Sie der Betriebsanleitung.

LEDs



LED	Farbe	Beschreibung
R	grün	Betriebssystem läuft
E	rot	Allgemeiner Fehler
D1	rot	Spezielle Zustände
D2	rot	Bootloader läuft
SD	gelb	Zugriff auf SD-Karte
U1 ... U4	gelb	Anwendungsspezifisch programmierbar

LED-Zustände beim Einschalten

Stufe	R	E	D1	D2	Beschreibung
1	 4Hz	 4Hz	 4Hz	 4Hz	Reset
2	 1Hz	 OFF	 OFF	 ON	Der Bootloader lädt und überprüft das Betriebssystem.
3	 1Hz	 OFF	 OFF	 OFF	Das Betriebssystem liest den DIP-Schalter auf dem JX3-Backplane-Modul und prüft das Vorhandensein des Ethernet-Switches.
4	 1Hz	 ON	 OFF	 OFF	Das Betriebssystem initialisiert Echtzeituhr, Ethernet-Schnittstelle und Dateisystem.
5	 1Hz	 ON	 ON	 OFF	Das Betriebssystem initialisiert die Module am JX3- und JX2-Systembus und die Software-Teile (Web, Modbus/TCP usw.); es lädt das Anwendungsprogramm.
6	 ON	 OFF	 OFF	 OFF	Normaler Betriebszustand

Schalter S11

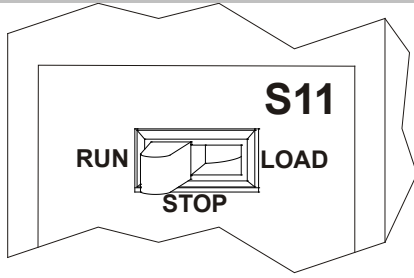

Stellung

Beschreibung

RUN

Steuerung JC-365 startet nach dem Einschalten das Anwendungsprogramm.

STOP

Steuerung JC-365 startet nicht das Anwendungsprogramm nach dem Einschalten.

LOAD

Steuerung JC-365 führt nach dem Einschalten die Datei **autocopy.ini** auf der SD-Karte aus.
Ist keine SD-Karte vorhanden, startet der Bootloader das Betriebssystem nicht.

Anschlussbeschreibung X10

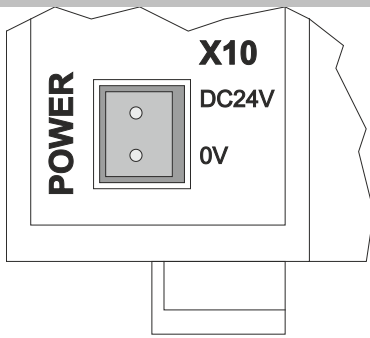

Klemmpunkt

Beschreibung

X10.DC24V

Versorgungsspannung für Steuerung JC-365 und angeschlossene JX3-Peripheriemodule

X10.0V

Bezugspotenzial

Technische Daten X10

Spannungsbereich:	DC 24 V, -15 % ... +20 %
Leistungsaufnahme:	Max. 1,5 A x 24,0 V = 36 W

Leiteranschluss X10

Technologie:	Zugfederanschluss
Schraubendreher:	SD 0,4 x 2,5 - DIN 5264-A
AWG:	16 ... 28
Eindrähtig:	H05(07) V-U 0,2 mm ² ... 1,5 mm ²
Feindrähtig:	H05(07) V-K 0,2 mm ² ... 1,5 mm ²
Mit Aderendhülse:	0,2 mm ² ... 1,5 mm ²
Aderendhülse mit Kragen:	0,2 mm ² ... 1,0 mm ²

Anschlussbeschreibung X11

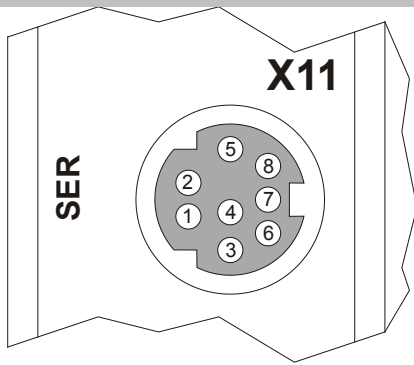

Pin	Signal	Beschreibung
1	RDA	RS-422, Rx invertiert
2	GND	Bezugspotenzial
3	RDB	RS-422, Rx nicht invertiert
4	RxD	RS-232; Rx
5	SDB	RS-422, Tx nicht invertiert
		RS-485, Rx/Tx nicht invertiert
6	DC24V	Versorgungsspannung Bediengerät
7	SDA	RS-422, Tx invertiert
		RS-485, Rx/Tx invertiert
8	TxD	RS-232; Tx

Technische Daten X11

Steckertyp:

MiniDIN, 8-polig, geschirmt

Spannung für Bediengerät
an X11.6:

Entspricht der Spannung an
X10.DC24V

Strom für Bediengerät
an X11.6:

Max. 0,5 A

Anschlussbeschreibung X19

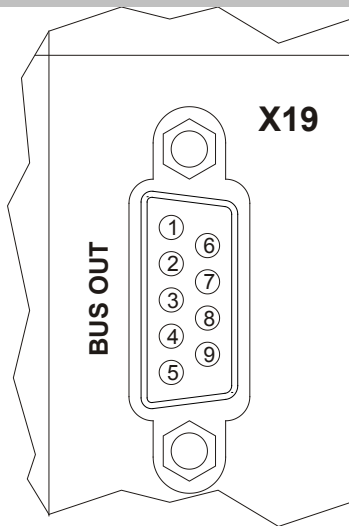

Pin	Signal
1	CMODE0
2	CL
3	GND
4	CMODE1
5	Unbenutzt
6	CL_2
7	CH
8	CH_2
9	Unbenutzt

Technische Daten X19

Steckertyp:

Sub-D 9-polig, Buchse

Hinweise zur EMV

- ✓ Beachten Sie die Application Note 016 *EMV-gerechte Schaltschrankinstallation*, die die Jetter AG erstellt hat.
Hinweis
Die Application Note 016 finden Sie im Downloadbereich auf unserer **Homepage <http://www.jetter.de>**.
- ✓ Weitere Informationen entnehmen Sie der Betriebsanleitung zur JC-365.

Anschlussbeschreibung X14/X15

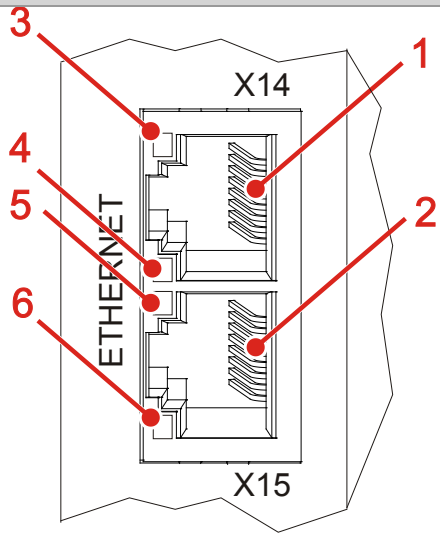

Nummer	Beschreibung
1	Buchse X14, Ethernet-Port
2	Buchse X15, Ethernet-Port
3	LED LINK: X14 mit einem Ethernet verbunden
4	LED ACT: JC-365 sendet oder empfängt über X14
5	LED LINK: X15 mit einem Ethernet verbunden
6	LED ACT: JC-365 sendet oder empfängt über X15

Technische Daten X14/X15

Übertragungsrate:	10 MBit/s, 100 MBit/s
Auto-crossover:	Ja
Klemmenart:	RJ45-Buchse
Leitungsart:	Cat 5e, geschirmt

SD-Karte stecken Steckplatz X61

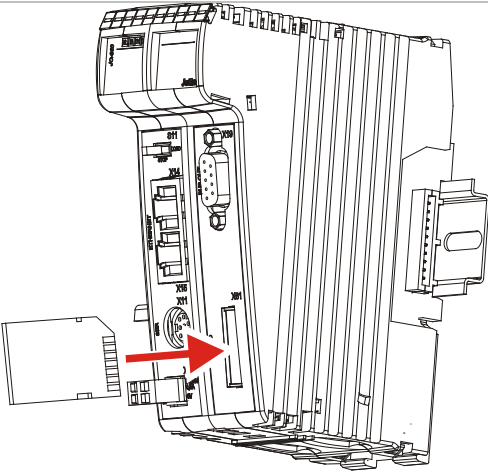
Schritt	Beschreibung	
1		<p>Stecken Sie die SD-Karte in der Position wie in der Abbildung beschrieben in den Steckplatz.</p> <p>Die Art und Weise, wie die SD-Karte gesteckt wird, ist dieselbe wie bei handelsüblichen Digitalkameras.</p>
⇒	<p>Wenn die SD-Karte richtig gesteckt ist, leuchtet die Status-LED SD der Steuerung für etwa 300 ms gelb auf.</p>	

SD-Karte entfernen Steckplatz X61

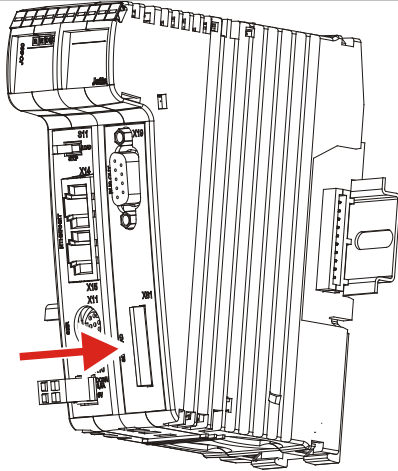
Schritt	Beschreibung
1	Greifen Sie nicht auf die SD-Karte zu, während Sie die SD-Karte entfernen. Schließen Sie davor alle Dateien, die auf der SD-Karte gespeichert sind.
2	 Durch Drücken und wieder Loslassen der SD-Karte löst sich diese aus der Arretierung und kann entfernt werden.
⇒	Wenn Sie die SD-Karte entfernt haben, leuchtet die Status-LED SD der Steuerung zweimal für 100 ms auf.

Technische Daten X61

Kartentyp:	SD-Karte, SDHC-Karte
Mechanismus:	push-push
Speicherplatz:	8 MByte ... 4 GByte
Formatierung:	FAT/FAT 32
Verdrehgeschützt:	Ja

Jetter AG

Graeterstrasse 2
D-71642 Ludwigsburg
Germany

Communication:

E-mail - Sales: sales@jetter.de
E-mail - Hotline: hotline@jetter.de
Phone - Hotline: +49(0)7141/2550-444

Installation Manual

Item # 60880620 | Revision 1.10

June 2018 / Printed in Germany

Download the user manual from
www.jetter.de, Downloads.

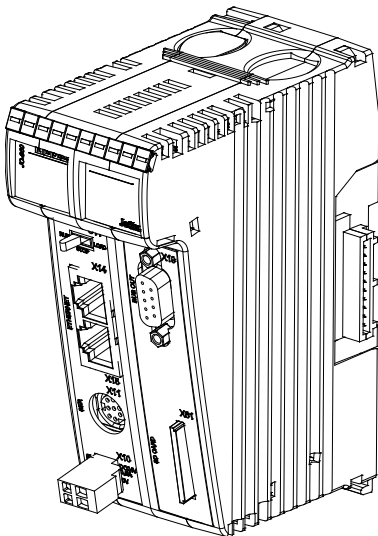

Scope of delivery

1 x	JC-365	Options: [MC]-[A]-[R]
1 x	60870409	2-pin connector, spring-cage connection
10 x	60870411	Terminal labels
1 x	60880620	Installation Manual

Installation on DIN rail to EN 50022

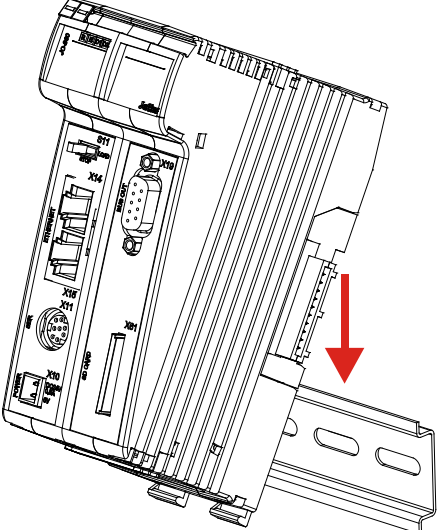
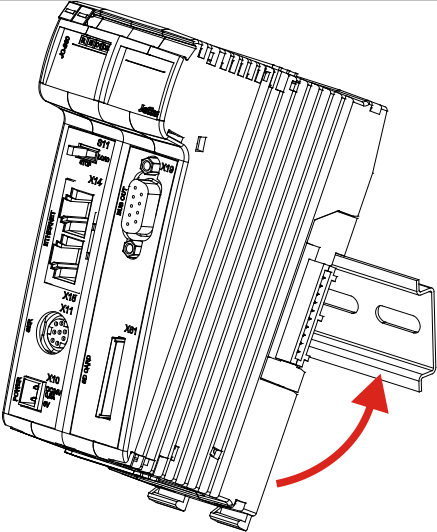
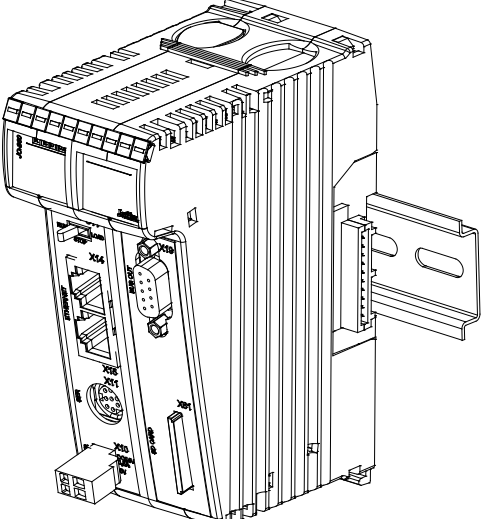
Step	Action
1	 <p>Place the JC-365 on the upper edge of the DIN rail.</p>
2	 <p>Move the JC-365 in the direction of the arrow until it snaps into place.</p>
3	 <p>Installation of the JC-365 to the DIN rail is now completed.</p>

Setting the IP address

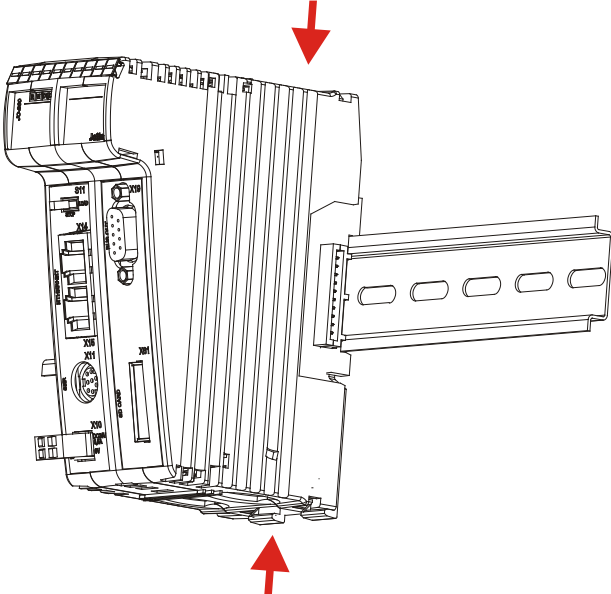
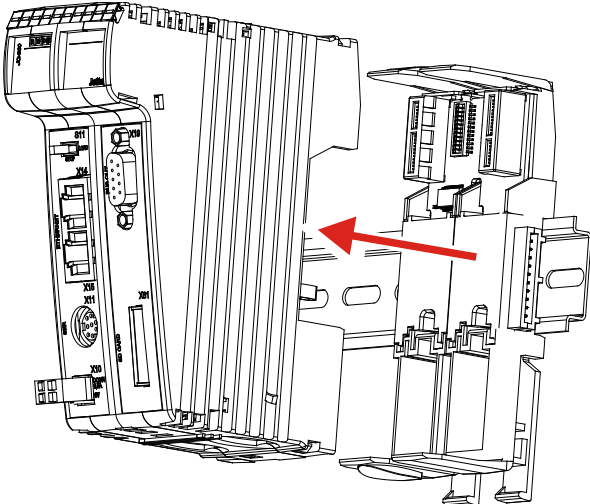
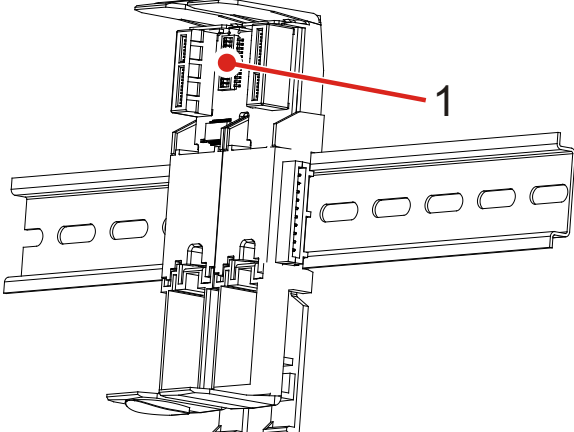
Step	Action
1	Remove power from the JC-365 and all JX3 modules connected to the JX3 station.
2	 <p data-bbox="970 389 1461 501">Press the upper and lower latches.</p>
3	 <p data-bbox="970 994 1331 1106">Pull off the JX3 enclosure.</p>
4	 <p data-bbox="970 1509 1430 1800">Now, the DIP switches (1) on the JX3 backplane module can be accessed.</p>

Setting the IP address

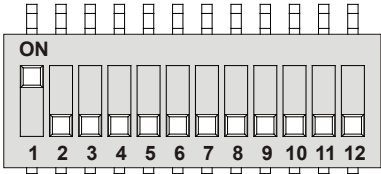
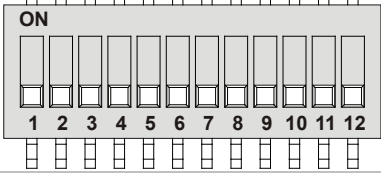
Step	Action
5	<p>Set the IP address using the DIP switches (1).</p> <p style="text-align: right;">IP address: 192.168.1.1 Factory settings</p>  <p style="text-align: right;">IP address: 192.168.10.15 Default IP address</p> 
6	Reattach the JX3 enclosure to the JX3 backplane module.
7	Restore the power supply of the JX3 station.





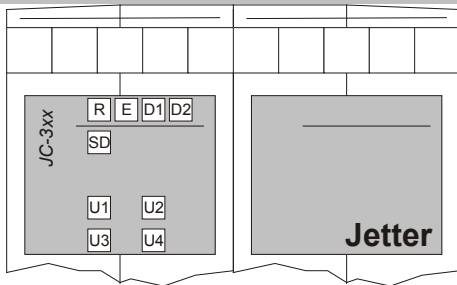



















For further information on setting the IP address, please refer to the user manual of the device.

LEDs



LED	Color	Description
R	Green	OS is running
E	Red	Generic error
D1	Red	Special conditions
D2	Red	Boot loader is running
SD	Amber	Access to SD card
U1 ... U4	Amber	Programmable depending on the application

LED states at power-up

Step	R	E	D1	D2	Description
1	 4Hz	 4Hz	 4Hz	 4Hz	Reset
2	 1Hz	 OFF	 OFF	 ON	Boot loader is running and is checking the OS.
3	 1Hz	 OFF	 OFF	 OFF	The OS reads the settings of the DIP switch on the JX3 backplane module and checks if an Ethernet switch exists.
4	 1Hz	 ON	 OFF	 OFF	The OS initializes realtime clock, Ethernet interface and file system.
5	 1Hz	 ON	 ON	 OFF	The OS initializes the modules on the JX3 and JX2 system bus, as well as software features (Web, Modbus/TCP, etc.); then it loads the application program.
6	 ON	 OFF	 OFF	 OFF	Normal operating condition

Mode selector S11

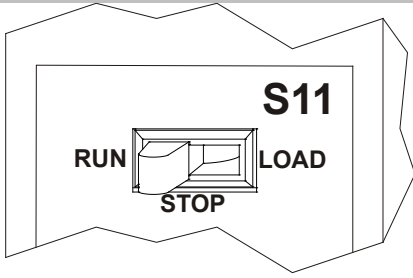

Position	Description
RUN	Once the JC-365 is turned on, it launches the application program.
STOP	When the JC-365 is turned on, the application program will not be launched.
LOAD	Once the JC-365 is turned on, it executes the file autocopy.ini which is located on the SD card. If there has no SD card been supplied, the boot loader does not start up the operating system.

Terminal X10 - Description

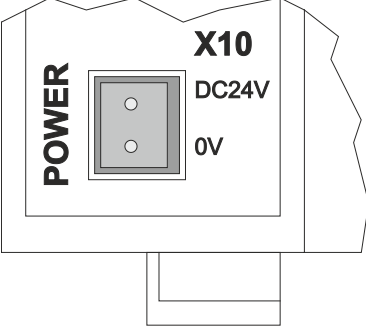
	Terminal point	Description
	X10.DC24V	Power supply for the JC-365 and connected JX3 peripheral modules
	X10.0V	Reference potential

X10 - Technical data

Input voltage range:	DC 24 V -15 % ... +20 %
Power consumption:	1.5 A x 24.0 V = 36 W max.

X10 - Wiring

Technology:	Spring-cage connection
Screwdriver:	SD 0.4 x 2.5 - DIN 5264-A
AWG:	16 ... 28
Solid conductor:	H05(07) V-U 0.2 mm ² ... 1.5 mm ²
Flexible conductor:	H05(07) V-K 0.2 mm ² ... 1.5 mm ²
With wire end ferrule:	0.2 mm ² ... 1.5 mm ²
Wire end ferrule with sleeve:	0.2 mm ² ... 1.0 mm ²

Connector X11 - Description

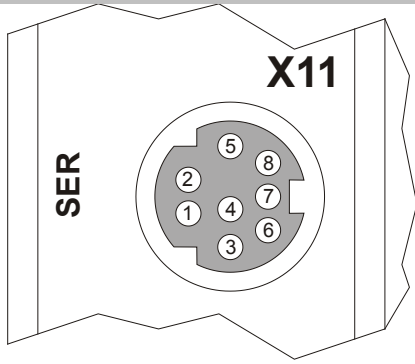

Pin	Signal	Description
1	RDA	RS-422, Rx inverted
2	GND	Reference potential
3	RDB	RS-422, Rx not inverted
4	RxD	RS-232; Rx
5	SDB	RS-422, Tx not inverted
		RS-485, Rx/Tx not inverted
6	DC 24 V	HMI supply voltage
7	SDA	RS-422, Tx inverted
		RS-485, Rx/Tx inverted
8	TxD	RS-232; Tx

X11 - Technical data

Connector type: MiniDIN, 8-pin, shielded

Voltage for the HMI at X11.6: It corresponds to the voltage at X10.DC24V

Current for the HMI at X11.6: 0.5 A max.

Connector X19 - Description

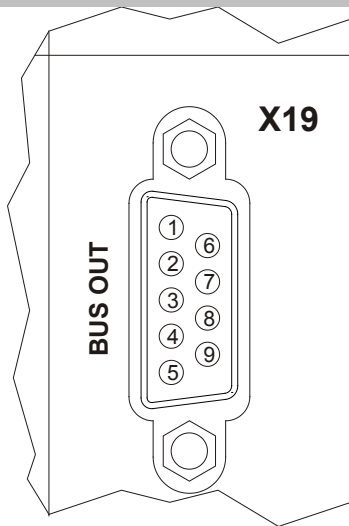

Pin	Signal
1	CMODE0
2	CL
3	GND
4	CMODE1
5	Unused
6	CL_2
7	CH
8	CH_2
9	Unused

X19 - Technical data

Connector type: 9-pin female SUB-D connector

Instructions on EMI

- ✓ Also refer to Application Note 016 *EMC-compatible installation of electric cabinets* by Jetter AG.

Note

For downloading the Application Note 016, please turn to our **homepage** <http://www.jetter.de>, **Downloads**.

- ✓ For further information please refer to the JC-365 user manual.

Connectors X14/X15 - Description

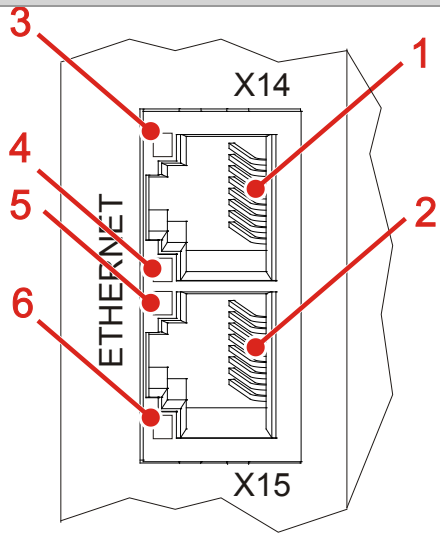

Number	Description
1	Female connector X14, Ethernet port
2	Female connector X15, Ethernet port
3	LED LINK: X14 is connected with Ethernet
4	LED ACT: JC-365 is transmitting or receiving signals via X14
5	LED LINK: X15 is connected with Ethernet
6	LED ACT: JC-365 is transmitting or receiving signals via X15

X14/X15 - Technical data

Bit rate:	10 MBit/s, 100 MBit/s
Auto-crossover:	Yes
Terminal type:	RJ45 Ethernet port
Cable category:	Cat 5e, shielded

Insert the SD card into slot X61

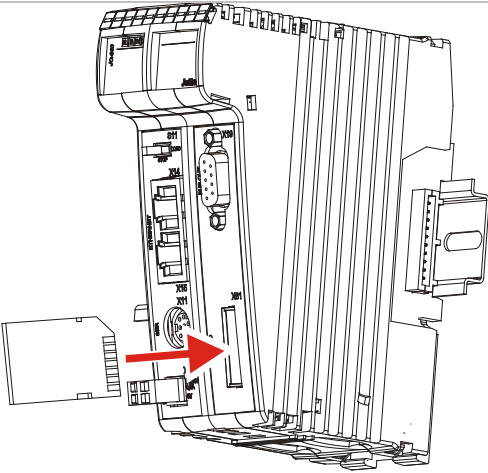
Step	Description
1	 <p data-bbox="922 259 1461 734">Insert the SD card into the SD slot as illustrated. The way of inserting the SD card correctly is the same as in common digital cameras.</p>
⇒	<p data-bbox="309 763 1401 925">If the SD card has been inserted correctly, the status LED SD of the controller lights up for approximately 300 ms.</p>

Remove the SD card from slot X61

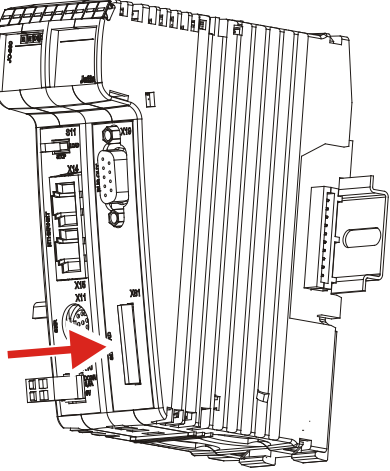
Step	Description	
1	Make sure the SD card is not accessed, while you are removing it. First, close all files which are stored to the SD card.	
2		To remove the SD card, press it further into the slot and let go again to release the lock. Now the SD card can be taken out.
⇒	After removing the SD card, the status LED SD of the controller lights up twice for 100 ms each time.	

X61 - Technical data

Board type:	SD card, SDHC card
Mechanical operation:	push/push
Memory:	8 MByte ... 4 GByte
Card format:	FAT/FAT 32
Protection against wrong card orientation:	Yes