

**Jetter AG**

Gräterstraße 2  
D-71642 Ludwigsburg  
Germany

**Kontakte:**

E-Mail - Vertrieb: sales@jetter.de  
E-Mail - Hotline: hotline@jetter.de  
Telefon - Hotline: +49(0)7141/2550-444

## Installationsanleitung

Version 1.00 | Artikel-Nr.: 60884758

November 2019 / Printed in Germany



(Abbildung ähnlich)

**Find english version below.**

### Lieferumfang

1 x	JI-FPC1015	Flatpanel PC
1 x	Montagezubehör	Befestigungsklammern, 3-poliger Anschlussstecker für die Versorgungsspannung
1 x	Grundlegende Sicherheitshinweise für IT-Systeme	Dokument
1 x	Installationsanleitung	Dieses Dokument

# Maße

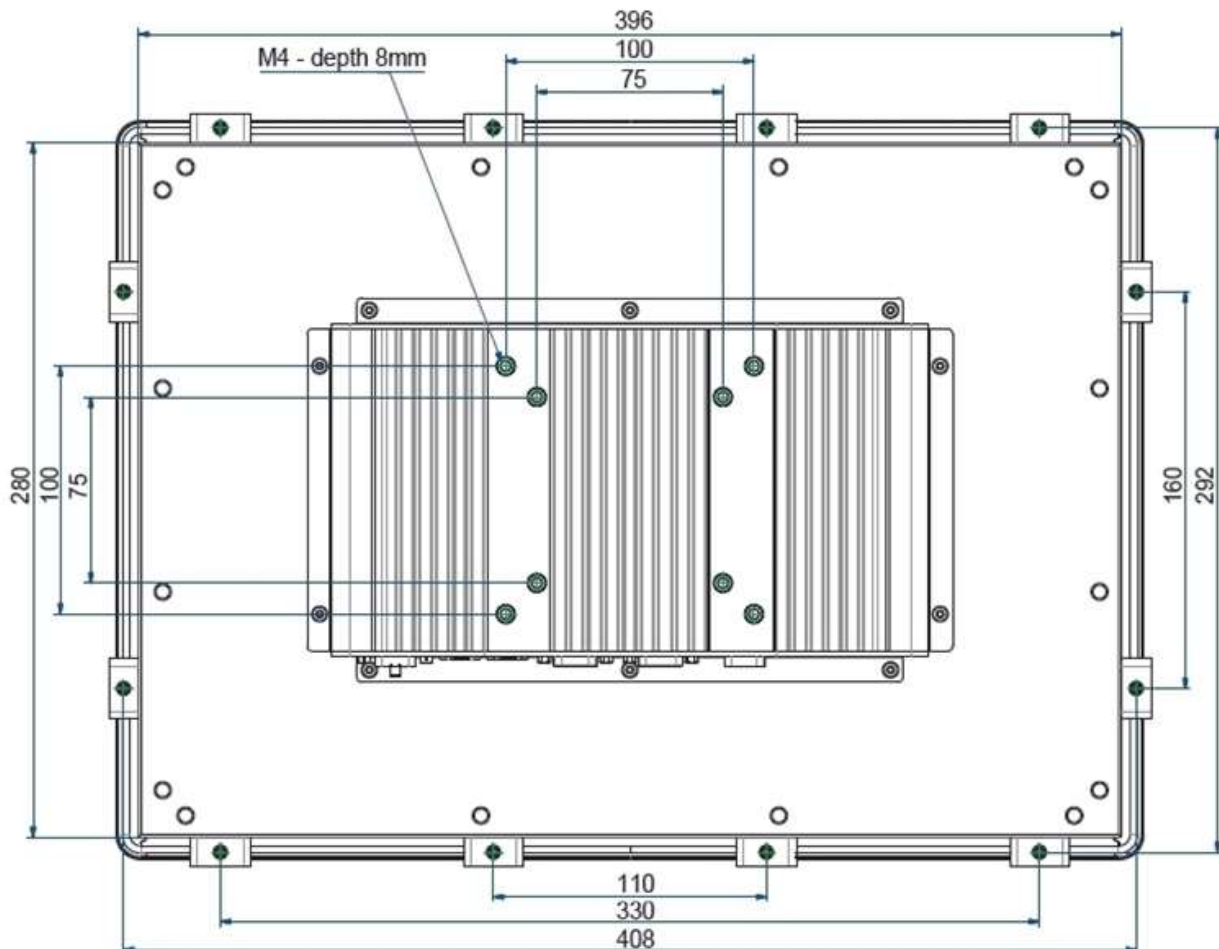
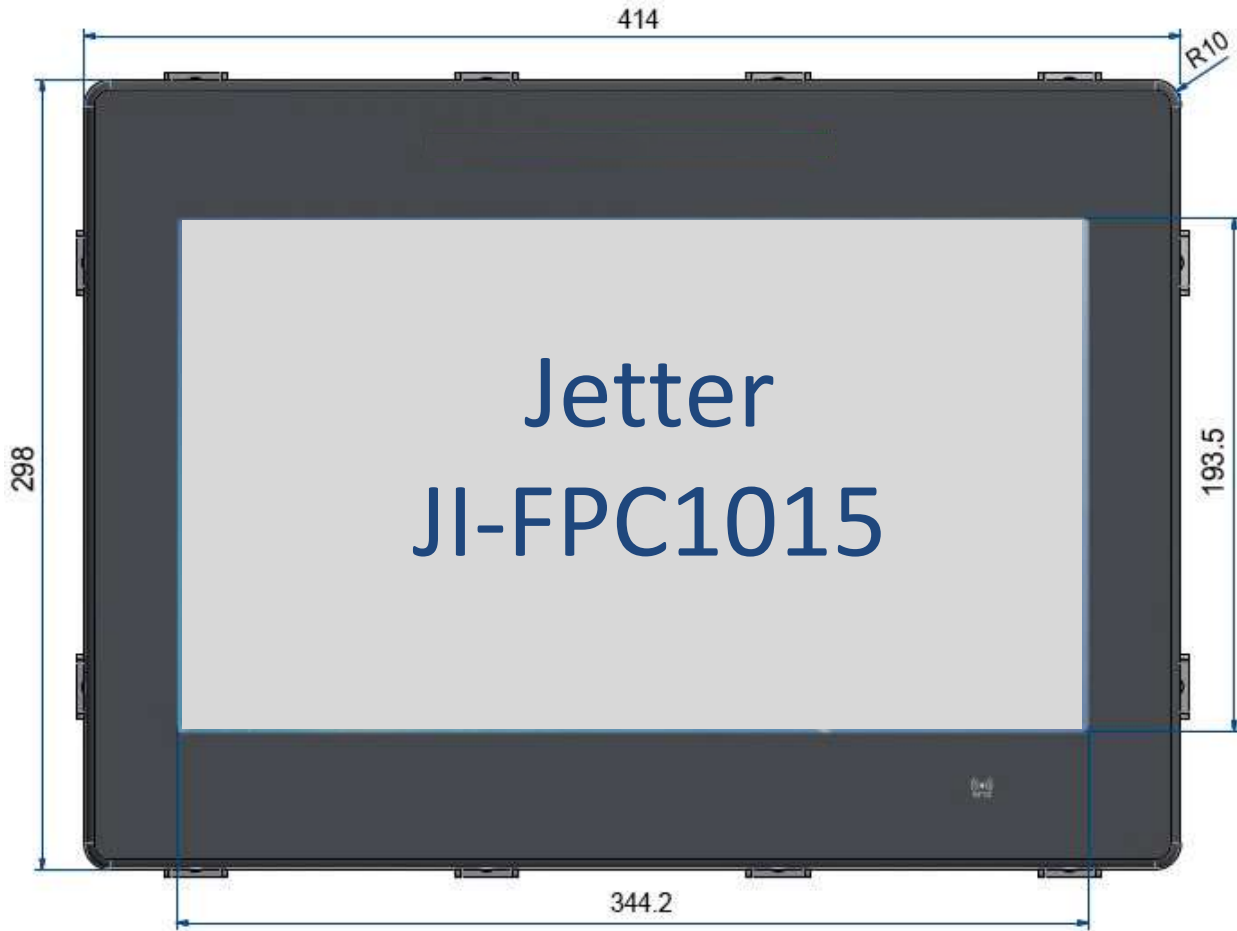

## Montage Fronttafeleinbau

Um den frontseitigen Schutzgrad von IP65 zu gewährleisten, achten Sie bitte auf den korrekten Zustand der Dichtung und eine glatte und saubere Oberfläche.

Achten Sie auf genügend Freiraum zum Anschluss der Kabel

Lassen Sie mindestens 5cm Freiraum (rückseitig) um das Gerät herum, damit eine entsprechende Luftzirkulation stattfinden kann.

Ausschnittmaß	398mm x 282mm
Empfohlene Wandstärke für korrekten Sitz	1,5mm – 6mm
Halteklammern	8 St. 
Werkzeug	Innensechskantschlüssel (INBUS®) 2mm
Anzugsmoment	0,7 Nm

## Ausschnittsmaße für Fronttafeleinbau



Achten Sie auf die korrekte horizontale und vertikale Ausrichtung.

## VESA 75/100 Montage

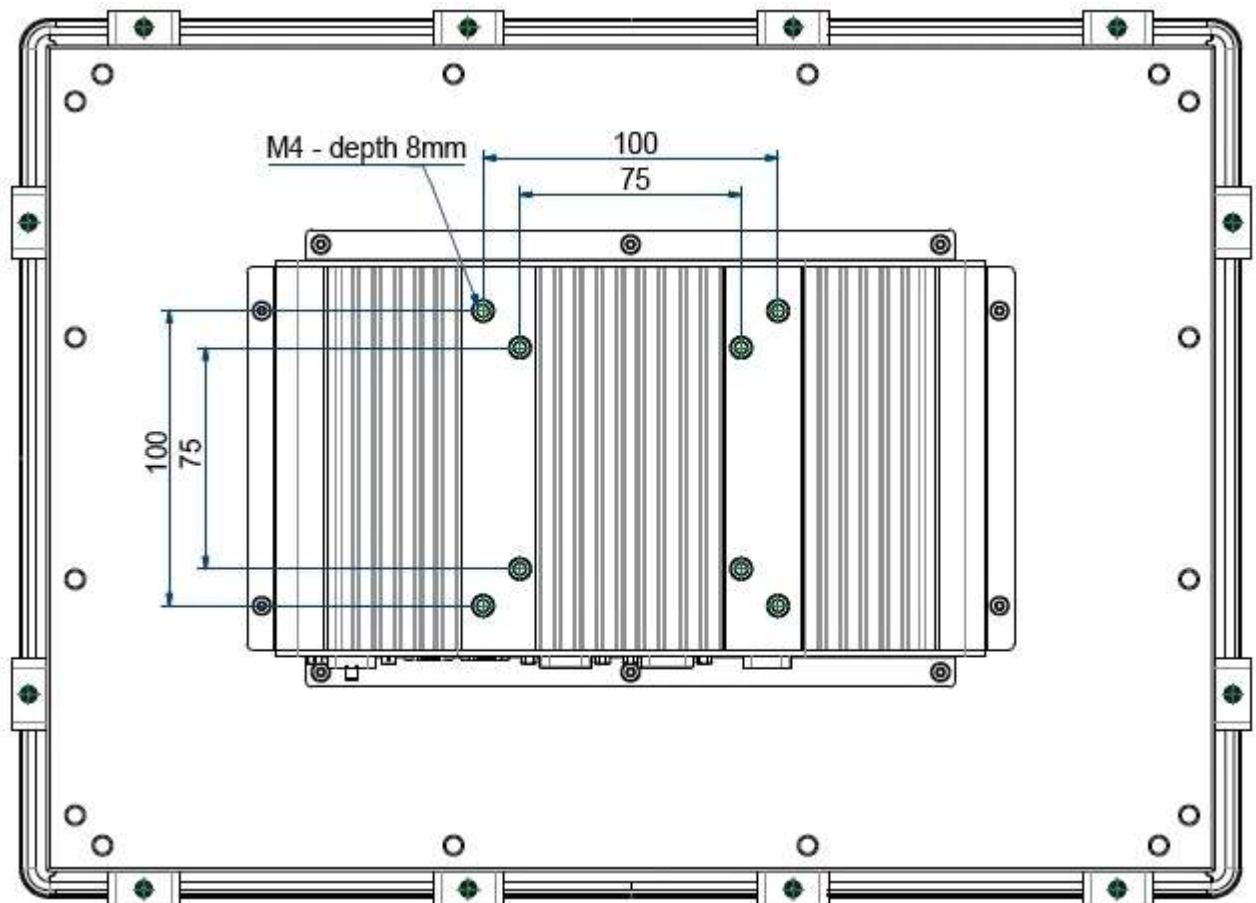

Der JI-FPC1015 kann auch in vertikaler Position an einer VESA 75/100 Befestigungsvorrichtung montiert werden. Das Gerät kann gedreht werden um die Bildschirmausrichtung im Quer- oder Hochformat zu ermöglichen.

### Mindestabstände

Um eine ausreichende Luftzirkulation zu gewährleisten, müssen bei der Montage des Geräts nach allen Seiten mindestens 5 cm Mindestabstand eingehalten werden.

# Anschlüsse

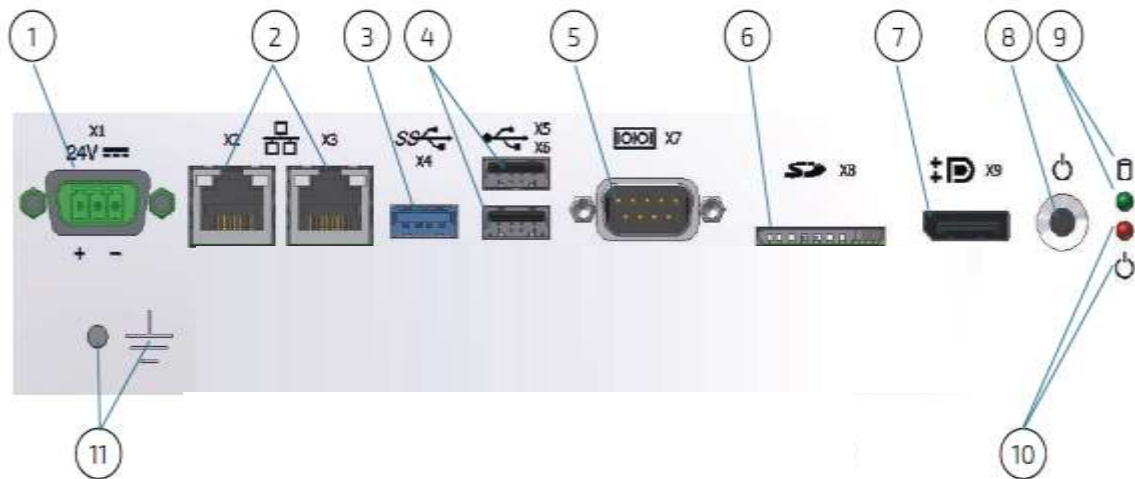

- |                            |                                     |
|----------------------------|-------------------------------------|
| 1.) (X1) Versorgung 24VDC  | 6.) (X8) SD-Card Steckplatz         |
| 2.) (X2,3) 2 x Ethernet    | 7.) (X9) Display Port               |
| 3.) (X4) 1 x USB 3.0       | 8.) EIN-/AUS-Schalter               |
| 4.) (X5,6) 2 x USB 2.0     | 9.) LED Aktivität<br>Massenspeicher |
| 5.) (X7) 1 x COM1 (RS-232) | 10.) LED Power                      |
|                            | 11.) Erdungsbolzen + Symbol         |

## Anschlussbeschreibung X1 Spannungsversorgung

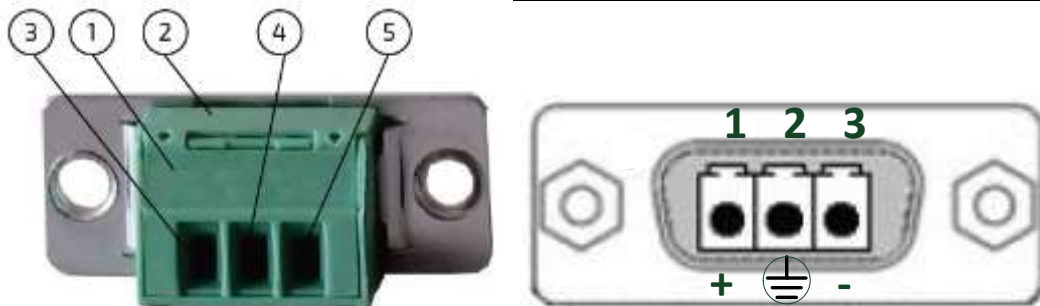

- |                             |                            |
|-----------------------------|----------------------------|
| 1.) Phoenix Stecker 3-polig | 4.) Klemme Schirmanschluss |
| 2.) Abdeckung Schrauben     | 5.) Klemme 0 V             |
| 3.) Klemme 10-30V DC        |                            |

## Anschlusswerte

Spannung	10 -30 V DC
Strom	3 A max.

## Anschlussbeschreibung X7 COM1 (RS-232)

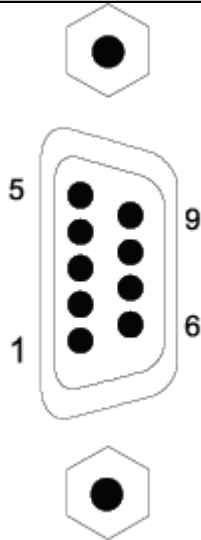

- 1 DCD (Data Carrier Detect)
- 2 RXD (Receive Data)
- 3 TXD (Transmit Data)
- 4 DTR (Data Terminal Ready)
- 5 GND (Signal Ground)
- 6 DSR (Data Set Ready)
- 7 RTS (Request to Send)
- 8 CTS (Clear to Send)
- 9 RI (Ring Indicator)

## Anschlussbeschreibung X9 DisplayPort

- 1 ML Lane 0 (p)
- 3 ML Lane 0 (n)
- 5 GND (ML Lane 1)
- 7 Lane 2 (p)
- 9 Lane 2 (n)
- 11 GND (ML Lane 3)
- 13 AUX SEL#
- 15 AUX CH (p)
- 17 AUX CH (n)
- 19 GND (GND\_DDC)

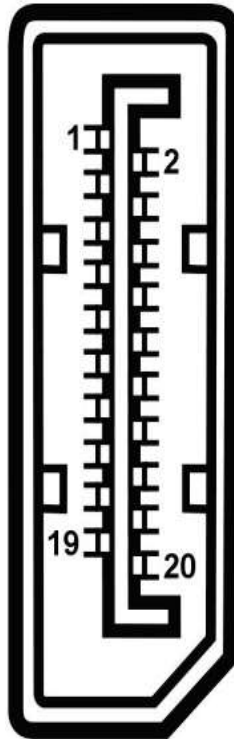

- 2 GND (ML Lane 0)
- 4 Lane 1 (p)
- 6 Lane 1 (n)
- 8 GND (ML Lane 2)
- 10 Lane 3 (p)
- 12 Lane 3 (n)
- 14 Pull-down to GND
- 16 GND (AUX CH)
- 18 Hot Plug
- 20 3.3V  
(DDC EEPROM  
Versorgung 500 mA  
max.)

## Anschlussbeschreibung X5,6 USB2.0 Ports

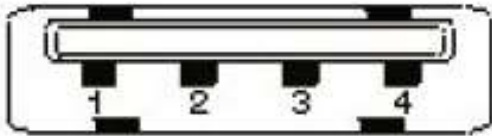

1 VCC (900 mA max.)
2 Data-
3 Data+
4 GND (Versorgung)

## Anschlussbeschreibung X4 USB3.0 Port

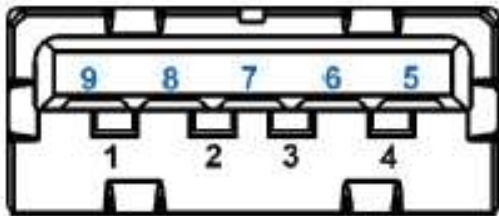

	USB2.0	USB3.0
1 VCC (900 mA max.)	5 StdA_SSRX-	
2 Data-	6 StdA_SSRX+	
3 Data+	7 GND_DRAIN	
4 GND (Versorgung)	8 StdA_SSTX-	
		9 StdA_SSTX+

## Anschlussbeschreibung X2,3 Ethernet (RJ-45)

linke LED      rechte LED

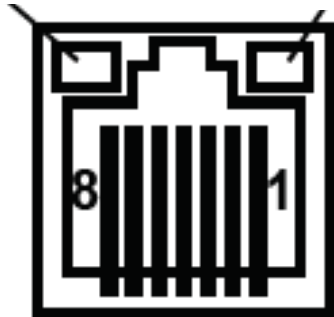

1 MDI0+
2 MDI01
3 MDI1+
4 MDI2+
5 MDI2-
6 MDI1-
7 MDI3+
8 MDI3-

## LED Statusanzeige

Linke LED		Rechte LED	
AUS	Keine Verbindung	AUS	10 Mbit/s
Grün, dauernd	Verbindung OK	Grün, dauernd	100 Mbit/s
Grün, blinkend	Verbindung OK mit Datenverkehr	Gelb, dauernd	1.000 Mbit/s





**Jetter AG**

Gräterstraße 2  
D-71642 Ludwigsburg  
Germany

**Communications**

E-Mail - Sales: sales@jetter.de  
E-Mail - Hotline: hotline@jetter.de  
Phone - Hotline: +49(0)7141/2550-444

## Installation Manual

Revision 1.00 | Item # 60884758

November 2019 / Printed in Germany



(Similar picture)

### Scope of delivery

1 x	JI-FPC1015	Flatpanel PC
1 x	Mounting accessories	Mounting clamps, DC power terminal
1 x	General safety instructions for IT equipment	Document
1 x	Installation Manual	This document

# Physical dimensions

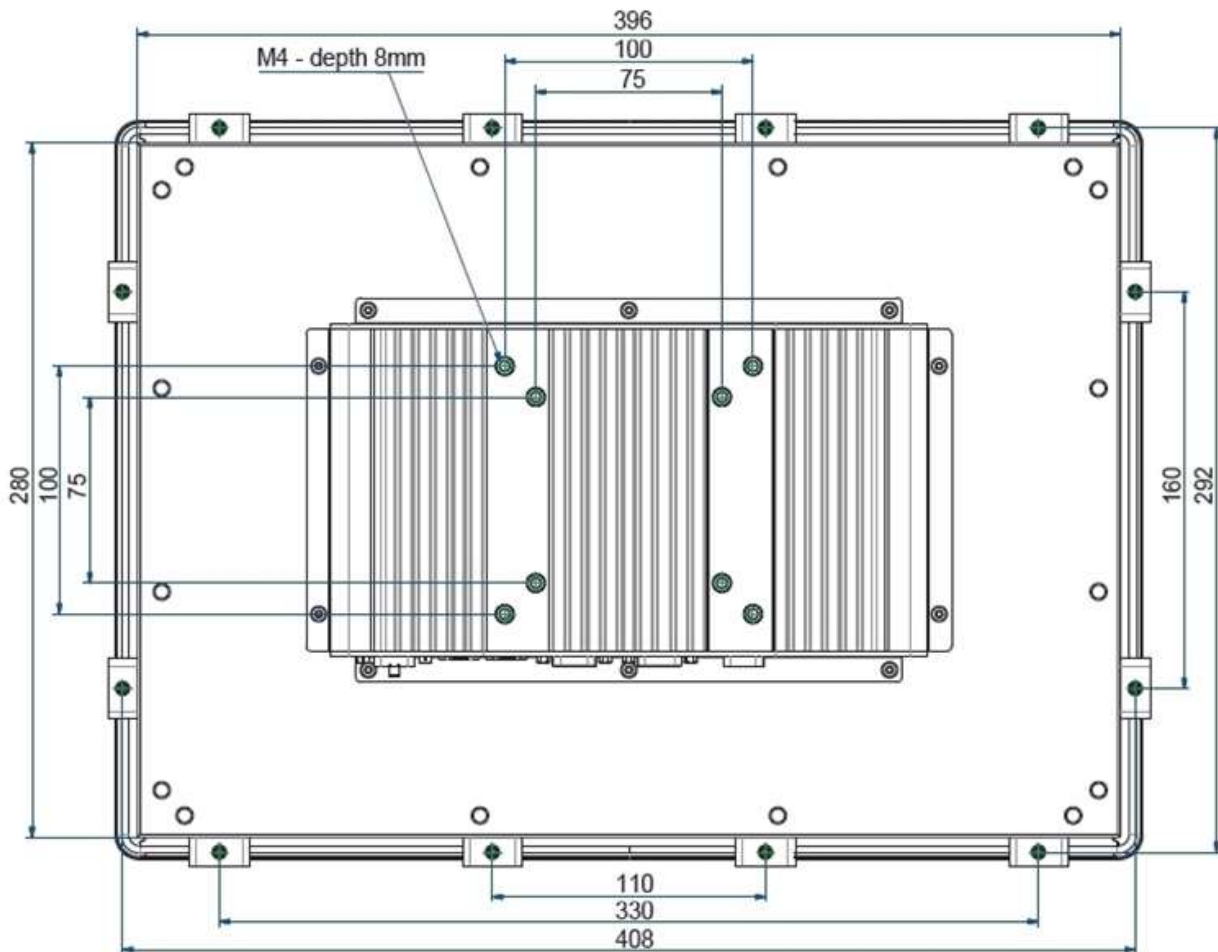
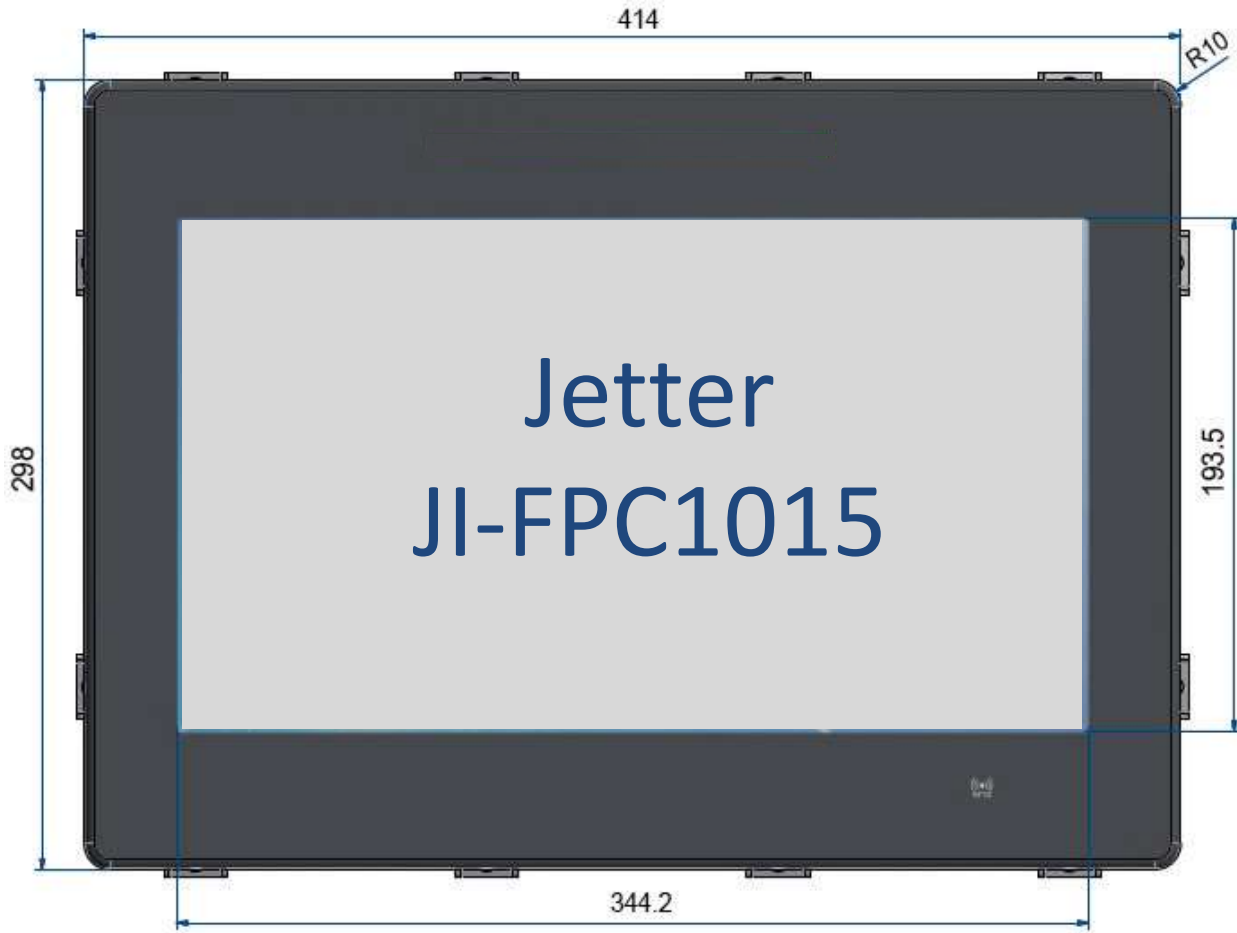



## Wall mounting

In order to ensure IP65 front sealing against dust and water, mount the system on a non-textured surface.

Keep clearance for cabling

Leave at least 5 cm of free space around the unit to prevent the device from possibly overheating! Do not obstruct the air intake and exhaust openings..

Cut-out for mounting to a wall/panel (W x H) [mm]	312mm x 250mm	
Thickness of the mounting wall/panel for proper mounting [mm]	1,5mm – 6mm	
Clamp with screws for mounting the FusionClient to a wall/panel	8 x 	=> 
Required tool	Allen Wrench 2mm	
Proper Torque	0,7 Nm	

## Wall / panel cut out dimensions

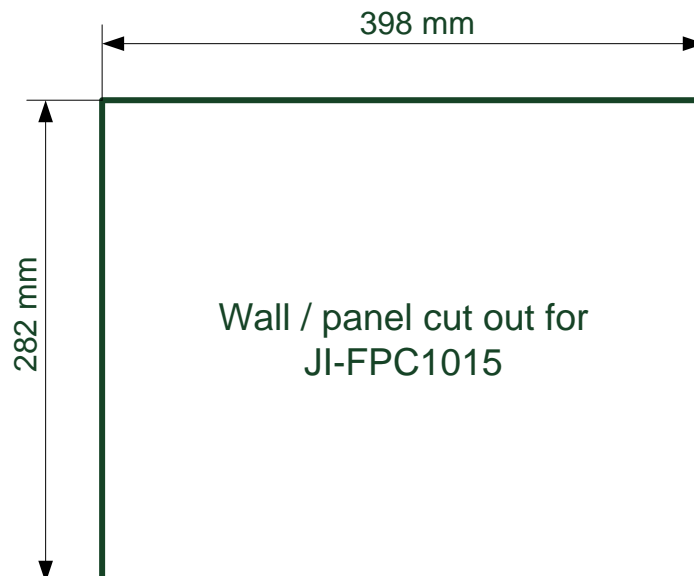

In order to ensure IP65 front sealing against dust and water, mount the system on a non-textured surface.

Ensure the vertical and horizontal alignment of the system/display unit.

## VESA 75/100 mounting

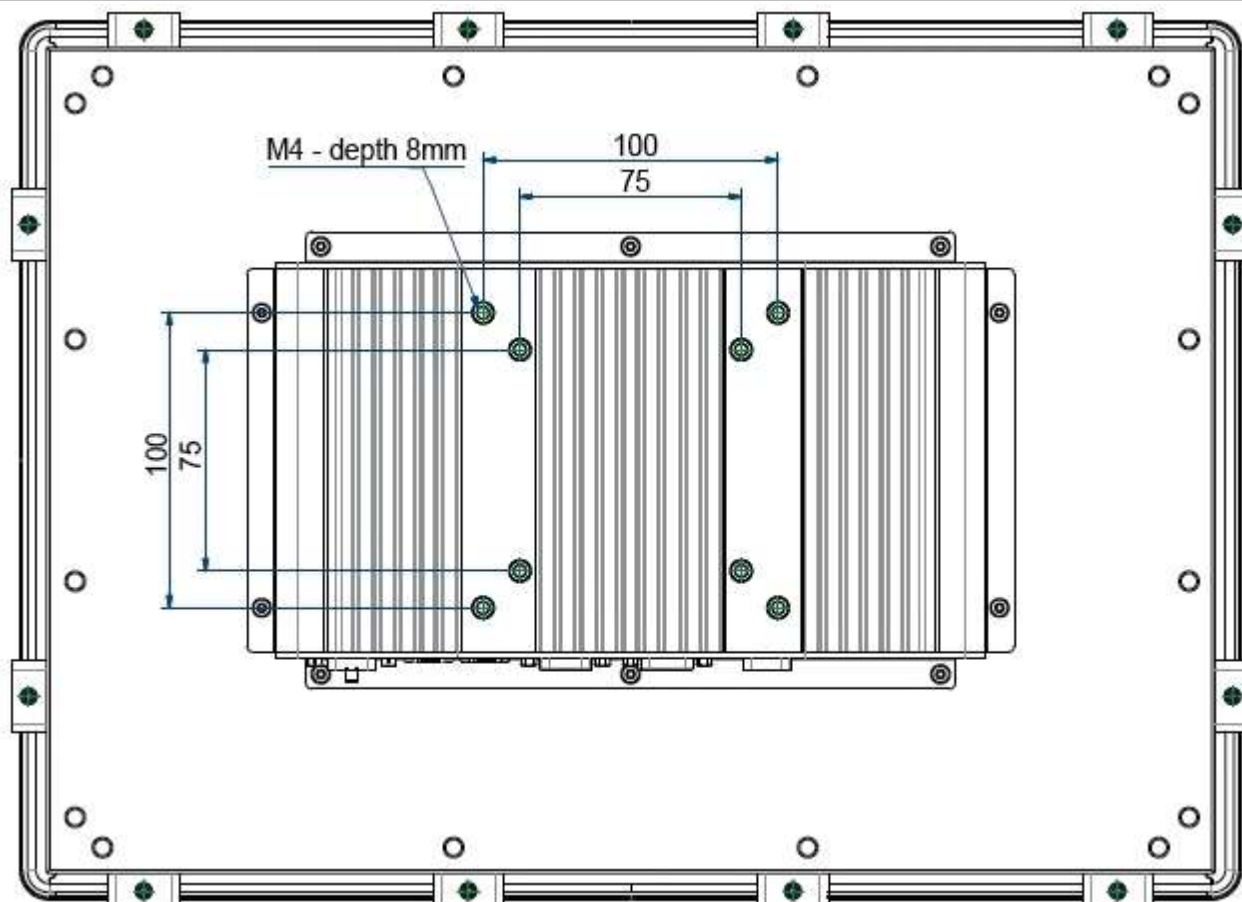

The FusionClient can be mounted to a VESA 75/100 compliant mounting system (in vertical position with the interfaces downwards). The FusionClient mounted to a VESA 75/100 compliant mounting system may be rotated to left or right in order to view landscape or portrait images if the installed operating system supports this feature. Ensure that the length of the cable connections to power and peripherals are sufficient for this operating position..

## Minimum spacing

Leave at least 5 cm (approx. 2") of free space around the unit to prevent the device from possibly overheating! Do not obstruct the air intake and exhaust openings.

The voltage feeds must not be overloaded. Adjust the cabling and the external overload protection to correspond with the rated voltage range indicated on the type label.

## Overview - Interfaces and connections

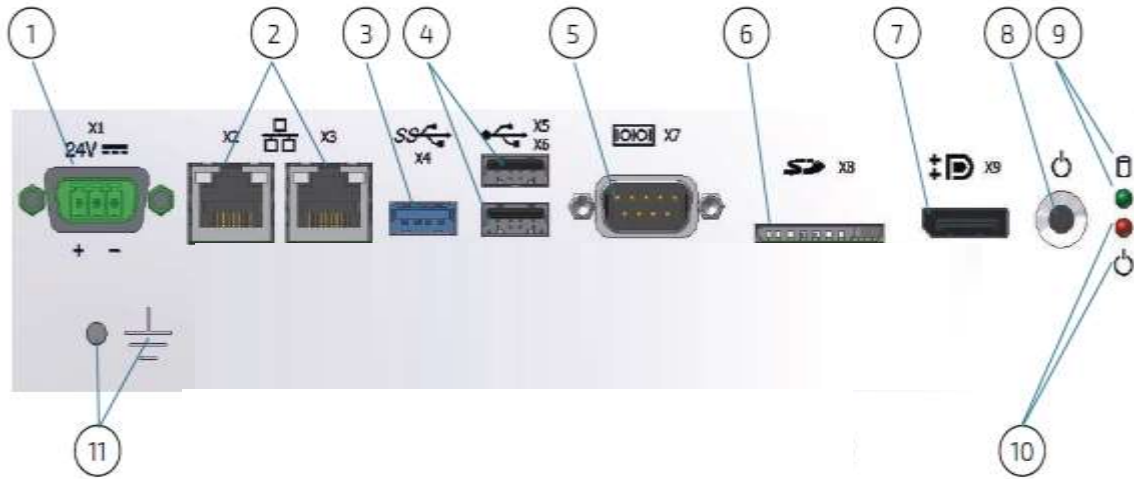

6.) (X1) Power supply

6.) (X8) SD-Card slot

7.) (X2,3) 2 x Ethernet

7.) (X9) Display port

8.) (X4) 1 x USB 3.0

8.) Power button

9.) (X5,6) 2 x USB 2.0

9.) LED storage activity

10.) (X7) 1 x COM1 (RS-232)

10.) LED Power

11.) Grounding stud and symbol

## X1 Power supply

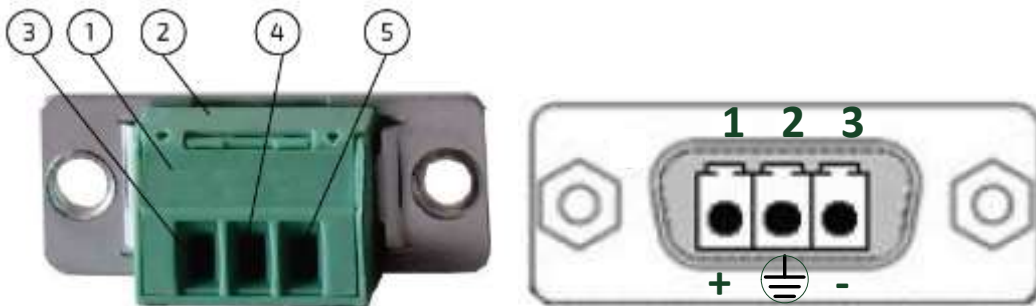

1.) 3-pin Phoenix plug terminal

4.) Shield terminal

2.) Cover pan head screws

5.) 0 V terminal

3.) 10-30V DC terminal

## Electrical specifications

Power supply

10 -30 V DC

Power consumption

3 A max.

## X7 COM1 (RS-232)

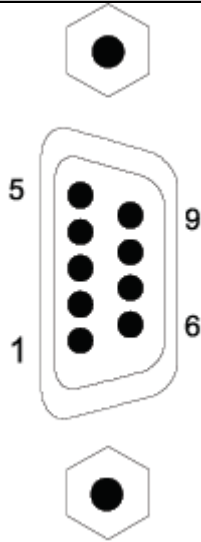

- |                             |
|-----------------------------|
| 1 DCD (Data Carrier Detect) |
| 2 RXD (Receive Data)        |
| 3 TXD (Transmit Data)       |
| 4 DTR (Data Terminal Ready) |
| 5 GND (Signal Ground)       |
| 6 DSR (Data Set Ready)      |
| 7 RTS (Request to Send)     |
| 8 CTS (Clear to Send)       |
| 9 RI (Ring Indicator)       |

## X9 Display port

- |                    |
|--------------------|
| 1 ML Lane 0 (p)    |
| 3 ML Lane 0 (n)    |
| 5 GND (ML Lane 1)  |
| 7 Lane 2 (p)       |
| 9 Lane 2 (n)       |
| 11 GND (ML Lane 3) |
| 13 AUX SEL#        |
| 15 AUX CH (p)      |
| 17 AUX CH (n)      |
| 19 GND (GND_DDC)   |

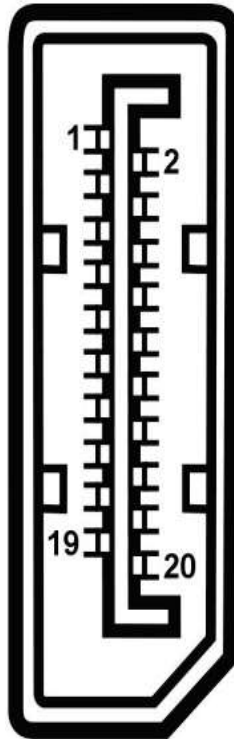

- |   |
|---|
| 2 GND (ML Lane 0)                       |
| 4 Lane 1 (p)                            |
| 6 Lane 1 (n)                            |
| 8 GND (ML Lane 2)                       |
| 10 Lane 3 (p)                           |
| 12 Lane 3 (n)                           |
| 14 Pull-down to GND                     |
| 16 GND (AUX CH)                         |
| 18 Hot Plug                             |
| 20 3.3V (DDC EEPROM power 500 mA fused) |

## X5 + X6 USB2.0 ports

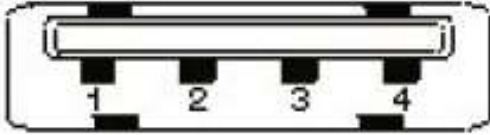

1	VCC (900 mA max.)
2	Data-
3	Data+
4	GND (ground for power return)

## X4 USB3.0 port

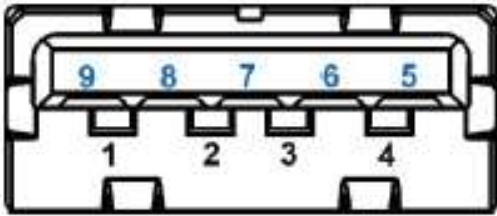

	USB2.0	USB3.0
1	VCC (900 mA max.)	5 StdA_SSRX-
2	Data-	6 StdA_SSRX+
3	Data+	7 GND_DRAIN
4	GND (ground for power return)	8 StdA_SSTX-
		9 StdA_SSTX+

## X2 +X3 Ethernet (RJ-45)

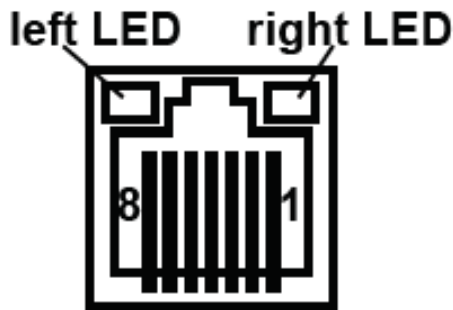

1	MDI0+
2	MDI01
3	MDI1+
4	MDI2+
5	MDI2-
6	MDI1-
7	MDI3+
8	MDI3-

## LED states

Left LED		Right LED	
OFF	Link not active	OFF	10 Mbit/s
Green, constant on	Link active	Green, constant on	100 Mbit/s
Green, flashing	Link active plus activity	Green, flashing	1.000 Mbit/s

