



## User Manual

JX3-THI2-RTD

This document has been compiled by Jetter AG with due diligence, and based on the known state of the art. Revisions and further development of our products are not automatically mentioned in a reviewed document. Jetter AG shall not be liable for errors in form or content, or for missing updates, as well as for damages or disadvantages resulting from such failure.



Jetter AG  
Graeterstrasse 2  
71642 Ludwigsburg  
Germany

**Phone**

Switchboard	+49 7141 2550-0
Sales	+49 7141 2550-531
Technical Hotline	+49 7141 2550-444

**E-mail**

Technical Hotline	hotline@jetter.de
Sales	sales@jetter.de

Translation of the original User Manual

Revision	2.04.1
Date of issue	8/6/2019

# Table of contents

<b>1 Introduction .....</b>	<b>5</b>
1.1 Information on this document .....	5
1.2 Typographical conventions.....	5
<b>2 Safety .....</b>	<b>6</b>
2.1 General information.....	6
2.2 Purpose .....	6
2.2.1 Intended use.....	6
2.2.2 Usage other than intended .....	6
2.3 Warnings used in this document .....	6
<b>3 Product description .....</b>	<b>7</b>
3.1 Design .....	7
3.2 Functions.....	7
3.3 Status indication .....	8
3.3.1 Diagnostics capabilities by means of status indication.....	8
3.4 Nameplate .....	8
3.5 Scope of delivery.....	9
<b>4 Technical specifications.....</b>	<b>10</b>
4.1 Dimensions.....	10
4.2 Environmental conditions .....	10
4.3 Electrical properties.....	11
4.4 Temperature inputs .....	11
4.5 Mechanical specifications.....	11
4.6 EMC values .....	12
4.6.1 Enclosure .....	12
4.6.2 DC power supply inputs and outputs.....	13
4.6.3 Shielded data and I/O lines .....	13
<b>5 Mechanical installation.....</b>	<b>14</b>
5.1 Installing the expansion module on the DIN rail .....	14
5.2 Removing the expansion module from the DIN rail.....	15
5.3 Dismounting the enclosure from the backplane module .....	16
<b>6 Electrical connection .....</b>	<b>17</b>
6.1 Temperature inputs X41, X42 .....	17
6.2 Connecting thermal sensors.....	18
6.3 Connection types of temperature sensors.....	18
<b>7 Programming.....</b>	<b>20</b>
7.1 Addressing within the system.....	20

---

7.1.1	Expansion modules connected with a controller .....	20
7.1.2	Expansion modules connected to an Ethernet bus node .....	21
<b>8</b>	<b>Registers - Overview.....</b>	<b>22</b>
8.1	Module code.....	22
8.2	General overview - Registers .....	22
8.3	Module state.....	22
8.4	Temperature inputs .....	23
8.5	Temperature inputs - Command registers.....	24
8.6	Temperature input status .....	25
8.7	Force value.....	26
8.8	Averaging .....	27
8.9	Monitoring limit values.....	27
8.10	Oscilloscope .....	27
8.11	Storing minimum/maximum values .....	29
8.12	Electronic nameplate.....	30
<b>9</b>	<b>Maintenance and repairs .....</b>	<b>31</b>
9.1	Maintenance, repairs and disposal.....	31
9.2	Storage and shipment .....	31
<b>10</b>	<b>Service .....</b>	<b>32</b>
10.1	Customer service .....	32
<b>11</b>	<b>Spare parts and accessories .....</b>	<b>33</b>
11.1	Spare parts.....	33
11.2	Accessories .....	33

# 1 Introduction

## 1.1 Information on this document

This document forms an integral part of the product and must be read and understood prior to using it. It contains important and safety-related information for the proper use of the product as intended.

### Target groups

This document is intended for specialists with appropriate qualifications. Only competent and trained personnel are allowed to commission and operate this device.

During the whole product life cycle, safe handling and operation of the device must be ensured. In the case of missing or inadequate technical knowledge or knowledge of this document any liability is excluded.

### Availability of information

Make sure this document is kept at the ready in the vicinity of the product throughout its service life.

For information on new revisions of this document, visit the download area on our website. This document is not subject to any updating service.

[Start | Jetter - We automate your success.](#)

For further information refer to the following information products:

- Version updates  
Information about new versions of software products or of the operating system of your controller.
- Online help of the JetSym software  
Detailed description of software functions with application examples
- Application-oriented manuals  
Information on file systems and communication interfaces

## 1.2 Typographical conventions

This manual uses different typographical effects to support you in finding and classifying information. Below, there is an example of a step-by-step instruction:

- ✓ This symbol indicates requirements which have to be met before executing the following action.
- ▶ This sign or a numbering at the beginning of a paragraph marks an action instruction that must be executed by the user. Execute the instructions one after the other.
- ⇒ The target after a list of instructions indicates reactions to, or results of these actions.

More information on this subject is available on our website.

[Start | Jetter - We automate your success.](#)

### INFO

"Info" provides you with useful information and practical tips about the product.

## 2 Safety

### 2.1 General information

At the time of placing on the market, this product corresponds to the current state of the art and meets the recognized safety rules.

Besides this user manual, laws and regulations in the operator’s country are relevant to the operation of the product. The operator is responsible for complying with the directives mentioned below:

- Applicable legislation, rules, and regulations
- Relevant accident prevention regulations
- Accepted safety rules
- EU directives and other country-specific regulations

### 2.2 Purpose

#### 2.2.1 Intended use

This expansion module was developed to add the temperature measurement feature to our controllers.

Operate the device only in accordance with the intended conditions of use, and within the limits set forth in the technical specifications.

Intended use of the product includes its operation in accordance with this manual.

**SELV**

The operating voltage of this device is classified as Safety Extra Low Voltage and is therefore not subject to the European Low Voltage Directive.



#### 2.2.2 Usage other than intended

This device must not be used in technical systems which to a high degree have to be fail-safe.

**Machinery Directive**

This device is no safety-related part as per Machinery Directive 2006/42/EC, and must, therefore, not be used for safety-relevant applications. This device is NOT intended for the purpose of personal safety, and must, therefore, not be used to protect persons.

### 2.3 Warnings used in this document

 <b>DANGER</b>	<b>High risk</b> Indicates an imminently hazardous situation which, if not avoided, will result in death or serious injury.
 <b>WARNING</b>	<b>Medium risk</b> Indicates a potential hazardous situation which, if not avoided, could result in death or serious injury.
 <b>CAUTION</b>	<b>Low risk</b> Indicates a hazardous situation which, if not avoided, could result in minor or moderate injury.
<b>NOTICE</b>	<b>Material damage</b> Indicates a situation which, if not avoided, could result in malfunctions or material damage.

### 3 Product description

The JX3-THI2-RTD expansion module serves in combination with one of our controls for temperature measurement. It has two independent inputs for temperature measurement with PT100/PT1000 sensors.

#### 3.1 Design

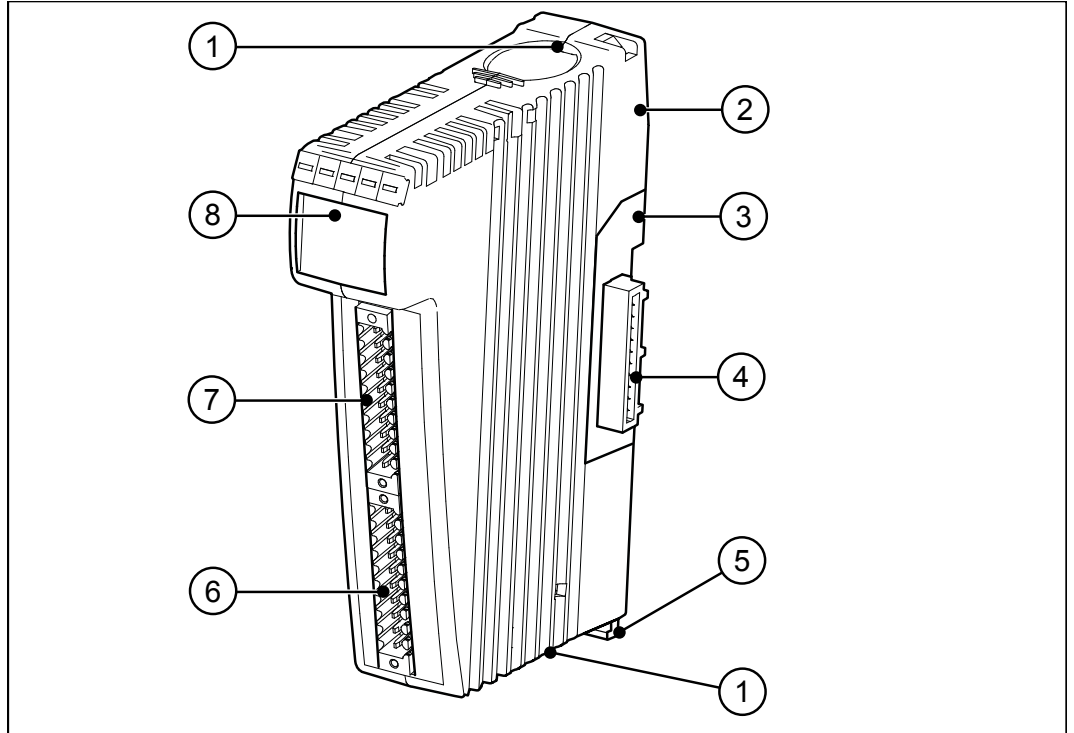

Fig. 1: Design of the device

1	DIN rail latch	2	Housing
3	Backplane module	4	Connectors for expansion modules
5	DIN rail release latch	6	Temperature input # 1
7	Temperature input # 2	8	Status indication

#### 3.2 Functions

- Moving averaging over 2 to 64 values
- Monitoring of limit values
- Storing minimum/maximum values
- Oscilloscope function
- Forcing
- Potentiometer mode

### 3.3 Status indication

LEDs indicate the communication state of the module and the state of the voltage supply.

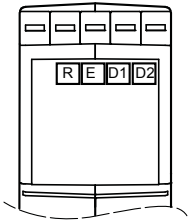

LED	Description	LED	Description
R	Logic circuit supply	D1	Hardware error
E	Communication with controller or bus node	D2	Operating system

Fig. 2: Status indication

#### 3.3.1 Diagnostics capabilities by means of status indication

Colors and flashing patterns of the LEDs are an excellent source of information to analyze problems.

Diagnostics capabilities are also offered in the Setup window of the JetSymb software.

LED	Flashing pattern	Color	Description
R	OFF	---	No logic circuit supply
	ON	Green	Logic voltage supply is OK
E	OFF	---	Communication with controller or bus node is active
	ON	Red	Communication with controller or bus node is Inactive
D2	Flashing	Red	There is no valid OS. Carry out an update.
	ON	Red	Cable breakage, short-circuit, excess or insufficient temperature on at least one channel
D1/D2	Flashing	Red	Operating system update

### 3.4 Nameplate

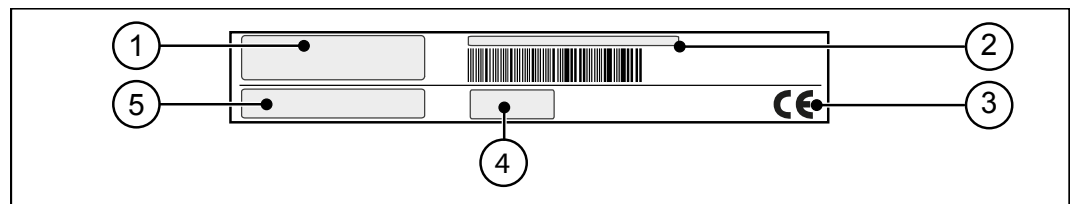

Fig. 3: Sample nameplate

1	Company logo	2	Serial number
3	CE marking	4	Hardware revision
5	Type key		



### 3.5 Scope of delivery

Scope of delivery	Item number	Quantity
JX3-THI2-RTD	10000570	1
Male connector in spring-cage technology, 10-pin	60869252	2
Terminal labels	60870411	10
Keying pins	60870410	1
Installation manual	60871746	1

## 4 Technical specifications

### 4.1 Dimensions

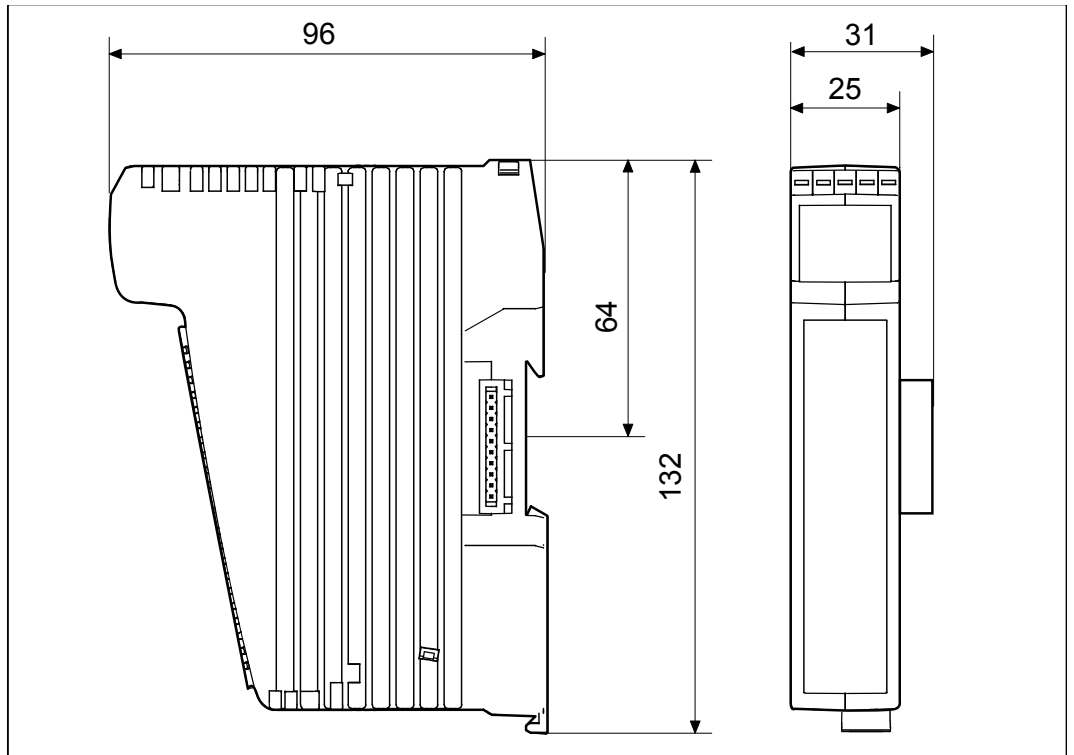

Fig. 4: Dimensions. All dimensions are in millimeters.

### 4.2 Environmental conditions

Category	Description	Standards
Operating temperature	0 °C ... +50 °C	DIN EN 61131-2
Storage temperature	-40 °C ... +70 °C	DIN EN 60068-2-1
Air humidity	10 ... 95 % non-condensing	DIN EN 60068-2-2
Max. operating altitude:	2,000 m above sea level	
Corrosion immunity and chemical resistance	No special protection against corrosion. Ambient air must be free from higher concentrations of acids, alkaline solutions, corrosive agents, salts, metal vapors, and other corrosive or electroconductive contaminants.	
<b>Degree of pollution - Electronics</b>		
Degree of pollution 2		DIN EN 61131-2
	Usually, the pollution is non-conductive. However, temporary conductivity due to condensation may occur.	

Tab. 1: Environmental conditions

### 4.3 Electrical properties

Category		Description
<b>Analog inputs:</b>		X41, X42
<b>Current consumption - backplane module:</b>		
From logic voltage	210 mA	
Power supply	The logic circuitry is supplied via the backplane module.	
From additional voltage	---	
<b>Measuring shunt</b>		
Type of sensor	Measuring range	Rated resistance at 0 °C
Pt100	10 Ω ... 1 kΩ	R0 = 100 Ω
Pt1000	100 Ω ... 6 kΩ	R0 = 1 kΩ
<b>Measured current:</b>		
Pt100	1.4 mA	
Pt1000	0.14 mA	

Tab. 2: Electrical properties

### 4.4 Temperature inputs

Category		Description
Connector	X41	X42
<b>Conversion time for measured temperature:</b>		
Slow Mode	Measurement in approx. 10 ms	
Fast Mode	Measurement in approx. 100 ms	
<b>Resolution of measurements:</b>		
The measurement resolution is influenced by various factors. Conversion time "Slow Mode", min. 20-fold averaging, ambient temperature approx. 25 °C, etc.		
	DIN IEC 60751, Class A	
Temperature range	-50 °C ... + 450 °C	+/- 0.5 °C
Temperature range	+450 °C ... 800 °C	+/- 1.0 °C

Tab. 3: Temperature inputs

### 4.5 Mechanical specifications

Category	Description	Standards
<b>Enclosure specifications</b>		
Material	Plastic	
<b>Maximum height of fall</b>		
Units within packing	1 m	DIN EN 61131-2
Units within product packaging	0.3 m	DIN EN 60068-2-31
<b>Vibration resistance</b>		
Frequency sweeps	1 octave/minute, sinusoidal	DIN EN 61131-2 DIN EN 60068-2-6
Constant amplitude	3.5 mm	5 Hz ≤ f ≤ 9 Hz
Constant acceleration	1 g	9 Hz ≤ f ≤ 150 Hz
Number and direction	10 sweeps for all 3 spatial axes	

Category	Description	Standards
<b>Shock resistance</b>		
Type of shock	Half-sine wave	DIN EN 61131-2 DIN EN 60068-2-27
Intensity and duration	15 g for 11 ms	
Number and direction	3 shocks in the directions of all 3 spatial axes	
<b>Degree of protection</b>		
Degree of protection	IP20	DIN EN 60529

Tab. 4: Mechanical specifications

## 4.6 EMC values

### 4.6.1 Enclosure

#### Electrical safety

Parameter	Values	Standard
Protection class	III	DIN EN 61131-2
Dielectric test voltage	Functional ground is connected to chassis ground internally.	
Overvoltage category	II	

Tab. 5: Electrical safety

#### Emitted interference

Parameter	Values	Standard
Frequency band	30 ... 230 MHz	DIN EN 61000-6-3 DIN EN 61131-2 DIN EN 55011
Limit value	30 dB (µV/m) at 10 m distance	
Frequency band	230 ... 1,000 MHz	
Limit value	37 dB (µV/m) at 10 m distance	
	Class B	

Tab. 6: Emitted interference

#### Immunity to interference

Parameter	Values	Standard
<b>RF field, amplitude-modulated</b>		
Frequency band	80 MHz ... 2 GHz	DIN EN 61131-2 DIN EN 61000-6-2 DIN EN 61000-4-3
Test field strength	10 V/m	
	AM 80 % at 1 kHz Criterion A	
<b>ESD</b>		
Discharge through air Test peak voltage 6kV	8 kV	DIN EN 61131-2 DIN EN 61000-6-2 DIN EN 61000-4-2
Contact discharge Test peak voltage 6kV	4 kV	

Tab. 7: Immunity to interference

### 4.6.2 DC power supply inputs and outputs

Immunity to interference

Parameter	Values	Standard
<b>Asymmetric RF, amplitude-modulated</b>		
Frequency band	0.15 ... 80 MHz	DIN EN 61131-2
Test voltage	10 V	DIN EN 61000-6-2
	AM 80 % at 1 kHz	DIN EN 61000-4-6
Source impedance	150 Ω	
	Criterion A	
<b>Bursts</b>		
Test voltage	2 kV	DIN EN 61131-2
	tr/tn 5/50 ns	DIN EN 61000-6-2
Repetition frequency	5 kHz	DIN EN 61000-4-4
	Criterion A	
<b>Surge voltages, symmetric, line to cable</b>		
Series-mode interference	tr/th 1.2/50 μs	DIN EN 61131-2
	0.5 kV	DIN EN 61000-6-2 DIN EN 61000-4-5
<b>Surge voltages, asymmetric, line to earth</b>		
Common-mode interference	tr/th 1.2/50 μs	DIN EN 61131-2
	0.5 kV	DIN EN 61000-6-2 DIN EN 61000-4-5

Tab. 8: DC power supply inputs and outputs

### 4.6.3 Shielded data and I/O lines

Immunity to interference

Parameter	Values	Standards
<b>Asymmetric RF, amplitude-modulated:</b>		
Frequency band	0.15 ... 80 MHz	DIN EN 61131-2
Test voltage	10 V	DIN EN 61000-6-2
	AM 80 % at 1 kHz	DIN EN 61000-4-6
Source impedance	150 Ω	
	Criterion A	
<b>Bursts</b>		
Test voltage	1 kV	DIN EN 61000-6-2
	tr/tn 5/50 ns	DIN EN 61000-6-2
Repetition frequency	5 kHz	DIN EN 61000-4-4
	Criterion A	
<b>Surge voltages, asymmetrical, line to earth:</b>		
	tr/th 1.2/50 μs	DIN EN 61131-2
Common-mode interference	1 kV	DIN EN 61000-6-2
Common-mode interference	0.5 kV	DIN EN 61000-4-5

Tab. 9: Immunity of shielded data and I/O lines

## 5 Mechanical installation

### 5.1 Installing the expansion module on the DIN rail

#### NOTICE

#### Functional impairment caused by unfavorable installation

- Install the device only in vertical position on the DIN rail.
- Keep the minimum distance to surrounding parts.

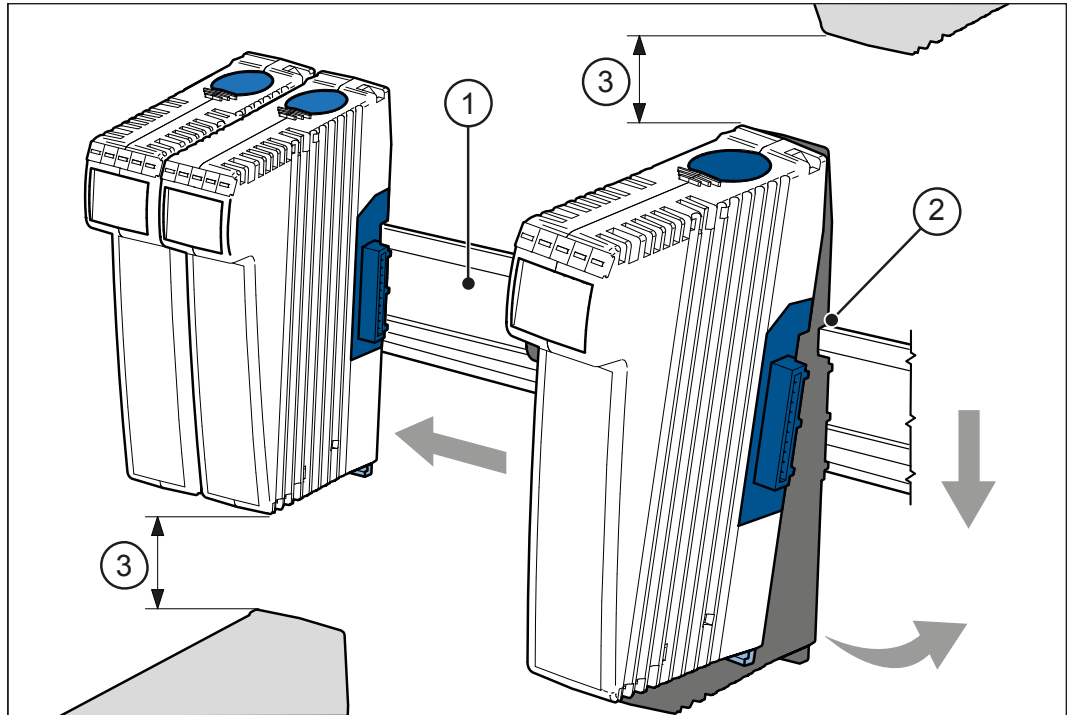

Fig. 5: Installing the expansion module on the DIN rail

1	DIN rail	2	Upper DIN rail latch
3	Minimum distance to surrounding parts = 30 mm		

1. Disconnect the system from the power supply.
2. Place the upper latch (2) in angled position on the DIN rail (1).
3. Snap the lower latch of the device onto the lower edge of the DIN rail.
4. Slide the device to its intended position.

## 5.2 Removing the expansion module from the DIN rail

The release latch lets you remove the device from the DIN rail.

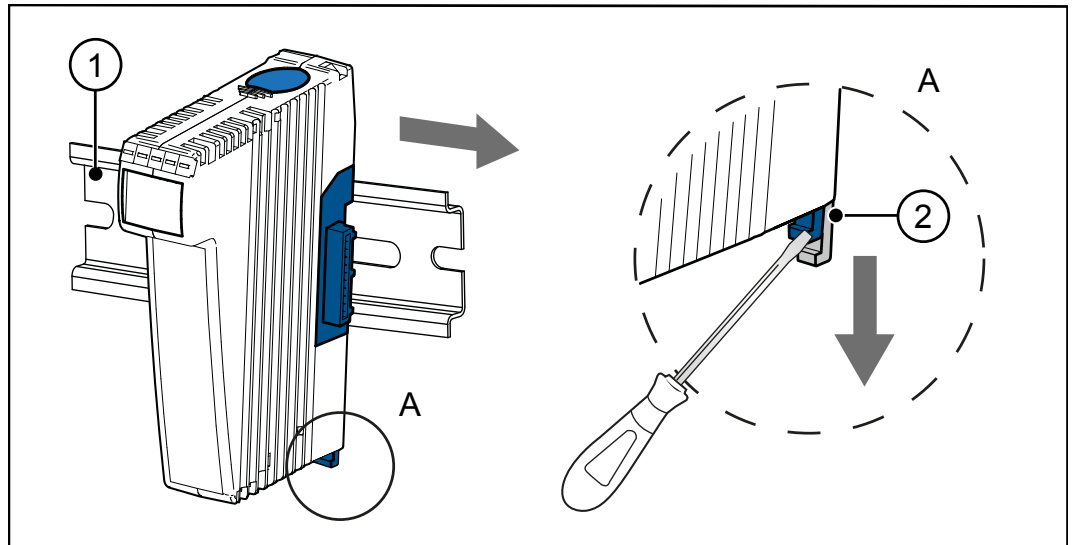

**Fig. 6:** Dismounting example

1	DIN rail	2	DIN rail release latch
A	Detail view		

1. Disconnect the system from the power supply.
2. Remove the device from the mains.
3. Pry the release latch (2) downwards and pull the device off the DIN rail (1).

### 5.3 Dismounting the enclosure from the backplane module

The upper and lower backplane tab on the module let you pull off the enclosure from the backplane module.

#### NOTICE

##### Mechanical damage and impaired EMC immunity

Protection class IP20 is not guaranteed when replacing JX3 modules. If you touch the EMC clip, you may damage this clip. A damaged clip may impair noise immunity.

- Do not touch any electronic components after removing the enclosure from the backplane module.

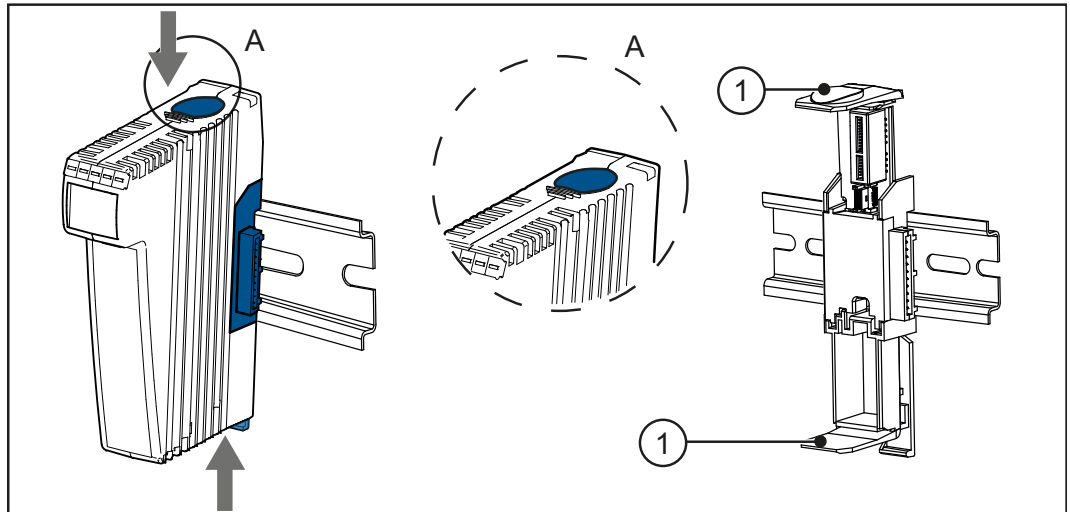

Fig. 7: Dismounting the enclosure from the backplane module

1	DIN rail latch	A	Detail view
---	----------------	---	-------------

1. Disconnect the system from the power supply.
2. Press the upper and lower latches (1) on the device simultaneously.
3. Keep the latches pressed and pull off the enclosure.



## 6 Electrical connection

### NOTICE

#### Improving electromagnetic compatibility

The noise immunity of a system is determined by its weakest component. Correct connections, lines and shielding are key factors.

- Ensure that the system is EMC-compliant.
- Follow the instructions given in Application Note 016 on our homepage about EMC-compatible installation of the electric cabinet.

### NOTICE

#### Damages to material or functional impairment

Improper implementation of the wiring harness may cause mechanical stress.

- Protect the cables from bending, twisting or chafing.
- Install strain reliefs for the connecting cables.

### 6.1 Temperature inputs X41, X42

The expansion module has two independent inputs for temperature measurement with PT100/PT1000 sensors.

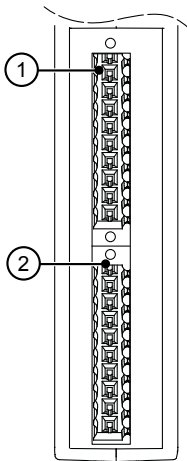

Position 1		Position 2	
Pin	X41	Pin	X42
I1+	Current path to sensor 1+	I2+	Current path to sensor 2+
U1+	Voltage path to sensor 1+	U2+	Voltage path to sensor 2+
U1-	Voltage path to sensor 1-	U2-	Voltage path to sensor 2-
I1-	Current path to sensor 1-	I2-	Current path to sensor 2-
0V	Ground	0V	Ground
BR1	Not assigned	BR3	Not assigned
BR2	Not assigned	BR4	Not assigned
0V	Ground	0V	Ground
SHLD	Shielding terminal	SHLD	Shielding terminal
SHLD	Shielding terminal	SHLD	Shielding terminal

## 6.2 Connecting thermal sensors

The connection of thermal sensors is identical for both inputs.

### INFO

To reduce interferences during temperature measurement, snap a split ferrite core around the sensor cable and a ferrite core around each connection cable within the sensor cable (e.g. by Würth Elektronik, part # 74271222). Attach the snap-on ferrite core as close as possible to the terminal.

- ✓ The system is de-energized.
  - ✓ A shielded cable is used.
1. Bridge the connections on the module according to the connection type mentioned in chapter [Connection types of temperature sensors \[▶ 18\]](#). Make sure there is a low-resistance connection and a low contact resistance at the bridges.
  2. Connect the cable of the thermal sensor to the module.
  3. Connect the shield of the cable to one of the SHLD connectors of the terminal.
  4. Connect the cable shield with the greatest possible surface area to a shielding terminal.

## 6.3 Connection types of temperature sensors

Depending on requirements and ambient conditions, temperature sensors can be connected in different ways.

### Two-wire mode and three-wire mode

The two-wire mode is not suitable for precision measurement because the resistance of the supply line influences the measurement results. The three-wire mode is recommended for longer cables. This solution corrects the resistance of the supply line.

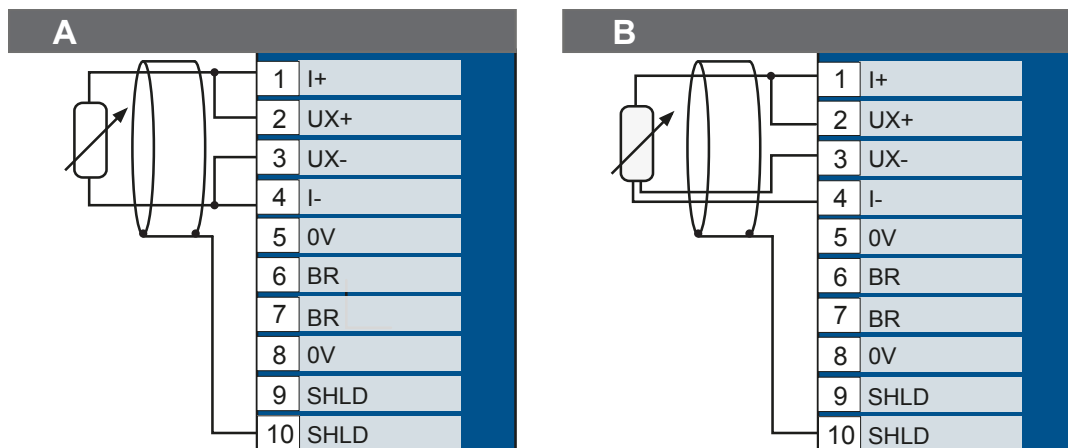
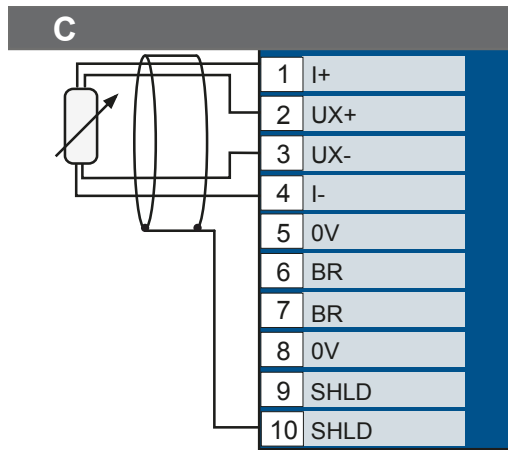

Fig. 8: Connection examples in two-wire and in three-wire mode

A	Two-wire mode	B	Three-wire mode
---	---------------	---	-----------------

### Four-wire and potentiometer mode

The four-wire mode offers a very high measuring accuracy. In potentiometer mode, the module records the total resistance and the partial resistance of the potentiometer and outputs the position of the potentiometer as a percentage.



**Fig. 9:** Connection examples in four-wire and potentiometer mode

C	Four-wire mode	D	Potentiometer mode
---	----------------	---	--------------------

## 7 Programming

### 7.1 Addressing within the system

Each expansion module has got 10,000 module registers.

These module registers are mapped to registers in the controller. Only controller registers let you read and write process, configuration, and diagnostic data of an expansion module. Controller registers can be accessed in the application program of the controller, in a setup pane of JetSym or via user interface.

The number of a controller register to which a module register has been mapped is influenced by the following parameters:

- Controller type
- Type of connection between controller and expansion module
- Position and amount of expansion modules in the system

The amount of expansion modules which can be connected to a controller depends on the type of the expansion module. After 8 expansion modules max., a power supply module must be inserted.

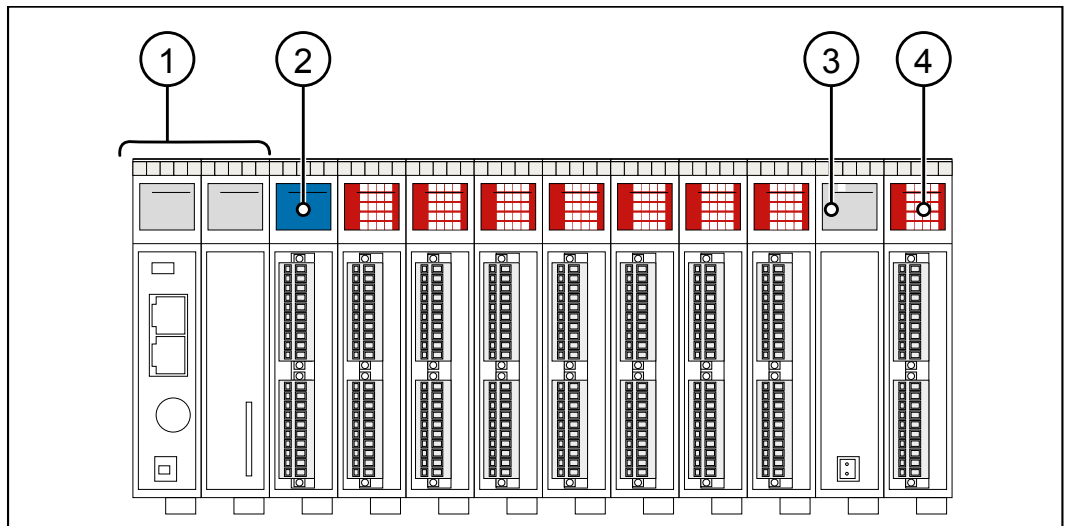

Fig. 10: Example: System overview of a controller together with various expansion modules

1	Controller	2	First expansion module
3	Power supply module	4	Further expansion modules

#### **i** INFO

You can calculate the exact amount of connectable expansion modules by means of the JX3-sysbus\_configurator\_xxx\_e which is available for download from our [Homepage](#).

#### **i** INFO

For more information on this subject refer to the application-oriented manual "JX3 System" available for download on our [website](#).

#### 7.1.1 Expansion modules connected with a controller

Our products offer a host of functions which can be accessed by the user via registers. Every register has got an unambiguous number, the register number. Each digital input or output has got an unambiguous I/O number.

## Register numbering system

Register numbers consist of a prefix, the module position in the system and the module register number. If the expansion modules are connected with the controller via JX3 system bus, the prefix is 100. In this case, the module register number is always a four-digit number.

100XXZZZZ

Fig. 11: Example: Register numbers

Digits	Description	value range
100	Prefix	
XX	Position of the module in the system	02 ... 17
ZZZZ	Module register number	0000 ... 9999

## I/O numbering system

The inputs or outputs of the module are directly accessed via I/O numbers. These I/O numbers consist of a five-digit prefix, the module position in the system and the I/O number of the module. The I/O numbers always start with the constant prefix 10000.

10000XXZZ

Fig. 12: Example: I/O numbers

Digits	Description	value range
10000	Prefix	
XX	Position of the module in the system	02 ... 17
ZZ	Module-specific I/O number	01 ... 16

### 7.1.2 Expansion modules connected to an Ethernet bus node

Ethernet bus nodes and controller communicate via Ethernet system bus. At addressing the expansion modules via Ethernet bus node, the Global Node Number (GNN) becomes part of the register number. The GNN is an ID number to identify controllers and Ethernet bus nodes within an Ethernet network.

## Register numbering system

The register numbers consist of a prefix, the GNN, the module position in the system and the module-specific register number.

1NNNXXZZZZ

Fig. 13: Example: Register numbers

Digits	Description	Value range
1	Prefix	
nnn	Bus node ID, GNN	001 ... 199
xx	Position of the module within the station	02 ... 17
zzzz	Module register number	0000 ... 9999

## I/O numbering system

Inputs or outputs of the module are directly accessed via I/O numbers. The I/O numbers consist of prefix 1, the GNN, prefix 2, the module position in the system and the module-specific I/O number.

1NNN01XXZZ

Fig. 14: Example: I/O numbers

Digits	Description	Value range
1	Prefix 1	
NNN	Bus node ID, GNN	001 ... 199
01	Prefix 2	
XX	Position of the module within the station	02 ... 17
ZZ	Module-specific I/O number	01 ... 16

## 8 Registers - Overview

### 8.1 Module code

For identification purposes, a unique module code is assigned to each module.  
 Module code JX3-THI2-RTD: 307

### 8.2 General overview - Registers

Register ranges	Description	
0	Module state	
2	Temperature value of channel # 1 as float	
3	Temperature value of channel # 2 as float	
7 ...	8	Module register for indirect access
	9	OS version
1100 ...	1199	Module register for channel # 1
1200 ...	1299	Module register for channel # 2
9470 ...	9474	Oscilloscope

### 8.3 Module state

Module register	0000
Description	Status and error messages of the module and of all analog channels
Type of access	Read access
Value range	Bit-coded, 32 bits
Value after reset	0x00210000 in faultless condition 0x40210000

Bit values	Description
<b>Bit 0</b>	<b>Hardware error</b>
0=	No error
1=	Hardware error
	The exact cause of the error can be determined by means of bit 4 through bit 7. Bit 0 can be set after bit 4 to bit 7 have been set.
<b>Bit 4</b>	<b>Error at reading calibration values</b>
0=	Calibration values were read without errors
1=	Hardware failure at reading the stored calibration values Maintenance service required This error cannot be fixed by the user.
<b>Bit 6</b>	<b>A/D converter error</b>
0=	No error
1=	Hardware failure at reading the analog input values of the A/D converter.
	The error can be acknowledged using command 5. If the error persists after an acknowledgement, the hardware is defective. Maintenance service required This error cannot be fixed by the user.
<b>Bit 7</b>	<b>Internal voltages</b>
0=	No error
1=	Internal voltages exceed the permitted limits.

Bit values		Description
<b>Bit 16</b>	<b>Takes effect</b>	<b>Type: Collective bit</b>
	0=	Invalid analog values in module registers 2 and 3.
	1=	Valid analog values in module registers 2 and 3.
		The collective bit is reset in the case of the following actions:
		When changing the configuration of the temperature input
		When changing the user-defined scaling
		After enabling or disabling the forcing function
		In case of an error regarding internal voltages
		When changing the averaging procedure
<b>Bit 17</b>	<b>No-load (cable breakage)</b>	<b>Type: Collective bit</b>
	0=	No error
	1=	At least one channel has exceeded the temperature limit. A broken cable may be the cause. The bit is set by the module It must be reset by the user.
<b>Bit 18</b>	<b>Short circuit</b>	<b>Type: Collective bit</b>
	0=	No error
	1=	At least one channel has fallen below the temperature limit. A short-circuit may be the cause. The bit is set by the module; it is reset by the user.
<b>Bit 19</b>	<b>Lower limit</b>	<b>Type: Collective bit</b>
	0=	No error
	1=	Value below lower limit At least one temperature input has fallen below the lower limit value. The bit is set by the module; it is reset by the user.
<b>Bit 20</b>	<b>Upper limit</b>	<b>Type: Collective bit</b>
	0=	No error
	1=	Value exceeds the upper limit. At least one temperature input has exceeded the upper limit value. The bit is set by the module It must be reset by the user.
<b>Bit 21</b>	<b>At least one measured value has been captured</b>	
	0=	No measured value has been captured
	1=	First measured value has been captured
<b>Bit 23</b>	<b>Forcing</b>	<b>Type: Collective bit</b>
	0=	Forcing function is disabled.
	1=	Forcing is enabled for at least one temperature input.
<b>Bit 30</b>	<b>Data exchange</b>	
	0=	Asynchronous data exchange with the controller or with the bus node
	1=	Synchronous data exchange with the controller or with the bus node

## 8.4 Temperature inputs

Module register	0002
Description	Digitized value of temperature input channel # 1
Type of access	Read access
Data type	Float
Value after reset	Analog value of temperature input # 1
Default value	The measured value is displayed in °C. The unit can be configured via <a href="#">Command registers [▶ 24]</a>

Module register 0003	
Description	Digitized value of temperature input channel # 2
Type of access	Read access
Data type	Float
Value after reset	Analog value of temperature input # 2
Default value	The measured value is displayed in °C. The unit can be configured via <a href="#">Command registers</a> [▶ 24]

## 8.5 Temperature inputs - Command registers

Module register 1y01	
Description	Command register
	Commands let you enable or disable various functions of the module.
	y = Temperature input # 1 or 2
Type of access	Read/write
Value range	8 bits
Value after reset	0

Com-mand	Description
6	Reset
	Reset in the case of cable breakage, short-circuit, excess or insufficient temperature
70	Resetting the lower limit value during min./max. value storage
71	Resetting the upper limit value during min./max. value storage
72	Resetting both limit values during min./max. value storage
102	Enabling two-wire mode
	The line resistance is included as an error in the measurement result.
103	Enabling three-wire mode
	The resistance of a line is measured and compensated.
104	Enabling four-wire mode
	The resistance of both lines is measured separately and compensated.
105	Fast Mode
	Measurement in approx. 10 ms
106	Slow Mode
	Measurement in approx. 100 ms
107	Switching the display to degrees centigrade
108	Switching the display to Fahrenheit
109	PT100
	Changing the measurement to PT100
110	PT1000
	Changing the measurement to PT1000
111	This instruction is for re-acquiring the line resistance $R_L$
112	Disabling the channel
	Re-enabling via commands
	102, 103, 104, 109, 110, 111



Command	Description
150	PT Measurement
	Measurement of the temperature sensor during operation. Toggling between 150/151 is possible.
151	Measurement R <sub>L</sub>
	Measurement of lead wire resistance during operation. Issue command 161 beforehand. Otherwise, the resistance is displayed as temperature value. Toggling between 150/151 is possible.
160	Display temperature in module register
161	Display resistance in module register
170	Disabling the force value
	Register 1y04 lets you assign a value to module register 0002 and 0003. Command 170 disables this option and displays the real reading in the module register.
171	Enabling the force value
	The value recorded in module register 1y04 is displayed. The status bits are set to indicate that the force value is enabled.
180	Disabling Potentiometer Mode
	Returning to normal measuring mode.
181	Enabling Potentiometer Mode
	If a value has been entered into module register 1y03, the reading is indicated in module register 0002 or 0003 as relative measurement in per cent of the reference value in register 1y03.
190	Enabling ice point compensation
	This instruction is for enabling ice point compensation. A relative temperature measured by the thermocouple is converted into an absolute temperature by adding the so-called ice point.
191	Disabling ice point compensation (not recommended)

### 8.6 Temperature input status

Module register	1y00
Description	Provides information about the status of a temperature input
	y = Temperature input # 1 or 2
Type of access	Read access
Value range	16 bits, bit-coded
Value range	4AC4 (hexadecimal), bits 2, 6, 7, 9, 11, 14 set

Bit values	Description
<b>Bit 0</b>	Fahrenheit or degree centigrade
	0= Displaying the reading in degrees centigrade
	1= Displaying the reading in degrees Fahrenheit.
<b>Bit 1</b>	2-wire measurement
	0= Disabled
	1= Enabled
<b>Bit 2</b>	3-wire measurement
	0= Disabled
	1= Enabled

Bit values	Description
<b>Bit 3</b>	4-wire measurement
0=	Disabled
1=	Enabled
<b>Bit 5</b>	Measuring mode
0=	Slow measuring mode (approx. 100 ms for a new reading)
1=	Fast measuring mode (approx. 10 ms for a new reading)
<b>Bit 6</b>	Validity of values of the given channel
0=	Invalid values
1=	Valid values
<b>Bit 7</b>	Channel Calibration
0=	Not calibrated
1=	Calibrated
<b>Bit 8</b>	Forcing
0=	Disabled
1=	Enabled
<b>Bit 9</b>	Type of thermal sensor
0=	Pt1000
1=	Pt100
<b>Bit 11</b>	Resistance value indication
0=	Resistance is displayed in module register 0002, respectively 0003
1=	Temperature value is displayed in module register 0002, respectively 0003.
<b>Bit 12</b>	Calibration mode
0=	Disabled
1=	Enabled
<b>Bit 13</b>	Potentiometer mode
0=	Disabled
1=	Enabled
<b>Bit 14</b>	Channel enabled/disabled
0=	Disabled
1=	Enabled
<b>Bit 15</b>	Reset
0=	No reset/normal measuring mode
1=	Initiating a reset (synchronously)

### 8.7 Force value

When forcing, the value from module register 1y04 is transferred to the controller instead of the analog value of a connected sensor. This way, the behavior of the connected sensor can be simulated during commissioning. This option allows also to test exceptional situations which do not occur during normal operation.

Activating and deactivating the Force function for an analog input and further information on this topic can be found under [Temperature inputs - Command registers \[▶ 24\]](#)

Module register	1y04
	Force value
Description	Simulated value of temperature input Y
Type of access	Read/write

Module register	1y04
Value range	Value x factor 1,000.
	Example: 123.456 corresponding to 123,456 °C
Value after reset	0

### 8.8 Averaging

Averaging attenuates the signal to suppress minor interference and noise. When the configuration is changed, the data of the temperature input become invalid. Bit 16 (collective bit Validity) of module register 0000 (Module state) is reset. Averaging starts anew.

Module register	1y06
Description	Configuration of averaging feature
Type of access	Read/write
Value range	0 ... 1: No averaging 2 ... 64: Averaging over the last 2 ... 64 values
Value after reset	20: Averaging over the last 20 values.

### 8.9 Monitoring limit values

After each A/D conversion, the module checks whether the converted averaged measured value has left a specified range. The range is defined by the user separately for each temperature input by a lower and upper limit.

Module register	1Y08
Description	Lower limit
	Defining the lower limit. The module checks with each conversion whether the value has fallen below the limit value.
Notation	The value is represented as x factor 1,000. Example: -50.7 °C displayed as -50.700
Type of access	Read/write
Data type	Integer
Value after reset	-50,000

Module register	1Y09
Description	Upper limit
	Defining the upper limit. The module checks with each conversion whether the limit has been exceeded.
Notation	The value is represented as x factor 1,000. 680.7 °C displayed as +680.700
Type of access	Read/write
Data type	Integer
Value after reset	-450,000

### 8.10 Oscilloscope

The integrated oscilloscope function lets you record values over a predefined period. The function can be launched via JetSym or via the application program. The values are then recorded on the device in a time grid of at least one millisecond, without taking up memory space from the controller. Then, the stored values can be loaded into the programming tool and displayed as graphs. This function allows you to easily calibrate the module.

<b>Module register 9740</b>	
	Oscilloscope function
Type of access	Read/write
Value range	0 ... 4
Value after reset	0
<b>Commands:</b>	
1	Starting a recording session The module starts recording immediately. Once the memory for measured values is filled, the module stops recording.
2	Stopping a recording session The module stops recording immediately.
3	A recording session is started once a trigger condition is fulfilled The module starts monitoring the trigger condition. Once the trigger condition is fulfilled, the module starts recording. Recording stops, when the memory for measuring values is full.
4	Starting continuous recording The module starts recording immediately. Recording is not stopped before issuing command 2.

<b>Module register 9741</b>	
	Parameter index
Description	Parameter index of module register 9742
Type of access	Read/write
Value range	0 ... 30

<b>Module register 9742</b>	
Description	Parameter value
	The parameter value is selected via parameter index.
Type of access	Read/write
Value range	32 bits
<b>Parameter:</b>	
0	Status (read-only)
Bit 0 = 1	Recording
Bit 1 = 1	Trigger enabled
2	Max. number of channels After reset, this parameter contains the maximum number of channels which can be recorded. The number of channels can be reduced by modifying this parameter. When doing so, the number of readings per channel increases accordingly. Value range: 1, 2
3	Max. number of readings per channel (read-only) Once a recording session is started, the module stores the readings for the configured channels. When the maximum number is reached, the recording session stops. The maximum number of readings depends on the number of channels which have been configured.
4	Minimum sampling interval (read only)

Module register 9742	
10	Sampling interval The sampling interval defines the intervals at which readings are recorded. The sum of sampling time and sampling duration gives the distance between two recordings in milliseconds. Value range: 1 ... 65,535
11	Number of the module register for oscilloscope channel # 1 Value range: 2, 3
12	Number of the module register for oscilloscope channel # 2 Value range: 2, 3
20	Number of the module register for oscilloscope trigger # 1 Value range: 2, 3
21	Value for trigger # 1 Module register value for trigger condition 1
22	Number of the module register for oscilloscope trigger # 2 Value range: 2, 3
23	Value for trigger # 2 Module register value for trigger condition 2
30	Size of the post-buffer Value range: 0 % ... 100 %

Module register 9743	
Description	Index of recorded values of module register 9744
Type of access	Read/write

Module register 9744	
Description	Recorded Values
Type of access	Read access

### 8.11 Storing minimum/maximum values

This function stores the smallest and largest value that occurs. The values stored get lost when the device is switched off.

Module register 1y20	
	Storing the minimum value
Description	The module register stores the minimum value.
Notation	The value is scaled with a factor of 1,000. Example: 123,456 corresponding to 123.456
Type of access	Read/write
Data type	Integer
Output format	°C, F, Ω
Value after reset	0

Module register 1y21	
	Storing the maximum value
Description	The module register stores the maximum value.
Notation	The value is scaled with a factor of 1,000. Example: 123,456 corresponding to 123.456

Module register 1y21	
Type of access	Read/write
Data type	Integer
Output format	°C, F, Ω
Value after reset	0

### 8.12 Electronic nameplate

Various production-relevant data are permanently stored in the nameplate. The EDS data can be read out from registers of the controller.

Register values		Description
100500 ...	100501	EDS data selection
100600 ...	100614	EDS Page 0 - Data
100700 ...	100710	EDS Page 1 - Data

Register values		Description
100500		Interface: 1= Position of the expansion modules in the system
100501		Module number within the system

Register values		Description
100600		Revision of EDS page 0
100601		Module code
100602 ...	100612	Module name
100613		Hardware revision
100614		Hardware option

Register values		Description
100700		Revision of EDS page 1
100701 ...	100707	Serial number of the module
100708		Production date: Day
100709		Production date: Month
100710		Production date: Year

## 9 Maintenance and repairs

### 9.1 Maintenance, repairs and disposal

<b>Maintenance</b>	<p>This device is maintenance-free. Therefore, for the operation of the device no inspection or maintenance are required.</p>
<b>Repairs</b>	<p>Defective components could cause dangerous malfunctions and could compromise safety. Only the manufacturer is allowed to repair the device. Do not open the device!</p>
<b>Disposal of obsolete equipment</b>	<p>The device must be disposed of in accordance with the Environmental Product Declaration EPD. Applicable local environmental directives and regulations must be complied with. This product must be disposed of as waste electronic equipment. Waste packaging material must be recycled or reused.</p>
<b>Modifications and alterations to the device</b>	<p>Modifications and alterations to the device and its functions are not allowed. In the case of modifications to the device, any liability is excluded.  The original parts are specifically designed for the device. Parts and equipment from other manufacturers must, therefore, not be used.  Any liability for any damages resulting from the use of non-original parts and equipment is excluded.</p>

### 9.2 Storage and shipment

<b>Storage</b>	<p>When storing the device observe the environmental conditions given in chapter "Technical specifications".</p>
<b>Shipment and packaging</b>	<p>The device contains electrostatically sensitive components which can be damaged if not handled properly. Damages to the device may impair its reliability.  To protect the device from impact or shock, it must be shipped in its original packaging, or in an appropriate protective ESD packaging. In case of damaged packaging inspect the device for any visible damage, and inform your freight forwarder and the Jetter AG of the damage caused during shipment. If the device is damaged or has been dropped, it is strictly forbidden to use it.</p>

## 10 Service

### 10.1 Customer service

Should you have any questions, suggestions, or problems, please don't hesitate to contact our service representatives. To contact them, please call our technical hotline or use the contact form on our homepage:

[Technical hotline | Jetter - We automate your success.](#)

You are also welcome to send an e-mail to our technical hotline:

[hotline@jetter.de](mailto:hotline@jetter.de)

Please supply the following information when contacting our technical hotline:

- Hardware revision and serial number  
For the hardware revision number, please refer to the nameplate.
- OS version  
To determine the operating system version, use the functions of the development environment.



## 11 Spare parts and accessories

### NOTICE

#### Inadequate accessories might cause damage to the product

Parts and equipment from other manufacturers might impede the function of the device and cause damage to the product.

- Only use accessories recommended by Jetter AG.

### 11.1 Spare parts

Component	Item no.:
10-pin connector, spring-cage technology	60869252
10-pin-connector, push-in connection	60869254
Keying pins	60870410
Terminal labels	60870411

### 11.2 Accessories

### INFO

The accessories are not part of the scope of delivery.  
Apt accessories can be obtained from Jetter AG.

Component	Item no.:
Strain relief	60870963
End clamp for DIN rail	60863970
Screwdriver	60871712

## List of figures

Fig. 1	Design of the device .....	7
Fig. 2	Status indication .....	8
Fig. 3	Sample nameplate .....	8
Fig. 4	Dimensions. All dimensions are in millimeters. ....	10
Fig. 5	Installing the expansion module on the DIN rail .....	14
Fig. 6	Dismounting example .....	15
Fig. 7	Dismounting the enclosure from the backplane module .....	16
Fig. 8	Connection examples in two-wire and in three-wire mode .....	18
Fig. 9	Connection examples in four-wire and potentiometer mode .....	19
Fig. 10	Example: System overview of a controller together with various expansion modules .....	20
Fig. 11	Example: Register numbers .....	21
Fig. 12	Example: I/O numbers.....	21
Fig. 13	Example: Register numbers .....	21
Fig. 14	Example: I/O numbers.....	21

## List of tables

Tab. 1	Environmental conditions .....	10
Tab. 2	Electrical properties .....	11
Tab. 3	Temperature inputs .....	11
Tab. 4	Mechanical specifications.....	11
Tab. 5	Electrical safety .....	12
Tab. 6	Emitted interference .....	12
Tab. 7	Immunity to interference .....	12
Tab. 8	DC power supply inputs and outputs.....	13
Tab. 9	Immunity of shielded data and I/O lines .....	13

Jetter AG  
Graeterstrasse 2  
71642 Ludwigsburg  
[www.jetter.de](http://www.jetter.de)

E-mail [info@jetter.de](mailto:info@jetter.de)  
Phone +49 7141 2550-0

60872310

We automate your success.