

JetWeb

JX2-OD8

Operator's Manual



Edition 1.1

Jetter AG reserves the right to make alterations to its products in the interest of technical progress. These alterations need not be documented in every single case.

This manual and the information contained herein have been compiled with due diligence. However, Jetter AG assumes no liability for printing or other errors or damages arising from such errors.

The brand names and product names used in this manual are trade marks or registered trade marks of the respective title owner.

How to Contact us:

Jetter AG
Gräterstraße 2
D-71642 Ludwigsburg
Germany

Telephone - Switchboard: ++49 7141/2550-0
Telephone - Sales: ++49 7141/2550-530
Phone - Technical Hotline: ++49 7141/2550-444

Telefax: ++49 7141/2550-425
E-Mail - Sales: sales@jetter.de
E-Mail - Technical Hotline: hotline@jetter.de
Internet Address: http://www.jetter.de

This Operator's Manual is an Integral Part of the JetWeb-Module JX2-OD8:

Model: _____
Serial No: _____
Year of Manufacture: _____
Order No: _____



To be entered by the customer:

Inventory No: _____
Place of operation: _____

© Copyright 2002 by Jetter AG. All rights reserved.

Significance of this Operator's Manual

This manual is an integral part of the JX2-OD8 module, and

- must be kept in a way that it is always at hand until the JX2-OD8 module will be disposed of;
- if the JX2-OD8 module is sold, alienated or loaned, this manual must be handed over.

In any case you encounter difficulties to clearly understand the manual, please contact the manufacturer.

We would appreciate any kind of suggestion and contributions on your part and would ask you to inform or write us. This will help us to produce manuals that are more user-friendly and to address your wishes and requirements.

From this JX2-OD8 module may result unavoidable residual risks to persons and property. For this reason, any person who has to deal with the operation, transport, installation, maintenance and repair of the JX2-OD8 module must have been familiarised with it and must be aware of these dangers.

Therefore, this person must carefully read, understand and observe this manual, and especially the safety instructions.

Missing or inadequate knowledge of the manual results in the loss of any claim of liability on part of Jetter AG. Therefore, the operating company is recommended to have the instruction of the persons concerned confirmed in writing.

Table of Contents

1	Safety Instructions	7
1.1	Ensure Your Own Safety	9
1.2	Instructions on EMI	10
2	Physical Dimensions	11
3	Operating Parameters	13
4	Technical Data	17
5	JX2-OD8 - Digital Output Module	19
5.1	Description of Connections	19
5.2	Description of LEDs	20
6	Access to Variables, Inputs and Outputs	21

1 Safety Instructions

The JX2-OD8 module is in line with the current state of the art. The JX2-OD8 module complies with the safety regulations and standards in effect. Special emphasis was given to the safety of the users.

Of course, the following regulations apply to the user:

- relevant accident prevention regulations;
- accepted safety rules;
- EC guidelines and other country-specific regulations.

Usage as Agreed Upon

Usage as agreed upon includes operation in accordance with the operating instructions.

The JX2-OD8 module is used to control machinery, such as conveyors, production machines, and handling machines.

The supply voltage of the JX2-OD8 module is DC 24 V. This operating voltage is classified as SELV (Safety Extra Low Voltage). The JX2-OD8 module is therefore not subject to the EU Low Voltage Directive.

The JX2-OD8 module may only be operated within the limits of the stated data.

Usage Other Than Agreed Upon

The JX2-OD8 module must not be used in technical systems which to a high degree have to be fail-safe, e.g. ropeways and aeroplanes.

If the JX2-OD8 module is to be run under surrounding conditions, which differ from the conditions mentioned in chapter 3: "Operating Parameters, page 13,, the manufacturer is to be contacted beforehand.

Who is Permitted to Operate the JX2-OD8 Module?

Only instructed, trained and authorised persons are permitted to operate the JX2-OD8 module.

Mounting and backfitting may only be carried out by specially trained personnel, as specific know-how will be required.

Maintaining the JX2-OD8 Module

The JX2-OD8 module is maintenance-free. Therefore, for the operation of the module no inspection or maintenance are required.

Decommissioning and Disposal of the JX2-OD8 Module

Decommissioning and disposal of the JX2-OD8 module are subject to the environmental legislation of the respective country in effect for the operator's premises.

Descriptions of Symbols



Danger

This sign is to indicate a possible impending danger of serious physical damage or death.



Caution

This sign is to indicate a possible impending danger of light physical damage. This sign is also to warn you of material damage.



Important!

This sign is to indicate a possible impending situation which might bring damage to the product or to its surroundings.



Note!

You will be informed of various possible applications and will receive further useful suggestions.



Enumerations are marked by full stops, strokes or scores.



Operating instructions are marked by this arrow.



Automatically running processes or results to be achieved are marked by this arrow.

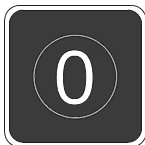

Illustration of PC and user interface keys.

1.1 Ensure Your Own Safety

- Disconnect the JX2-OD8 module from the mains to carry out maintenance work. By doing so, you will prevent accidents resulting from electric voltage and moving parts.
- Safety and protective devices, e.g. the barrier and cover of the terminal box must never be shunted or by-passed.
- Dismantled protective equipment must be reattached prior to commissioning and checked for proper functioning.

Modifications and Alterations to the Module

For safety reasons, no modifications and changes to the JX2-OD8 module and its functions are permitted. Any modifications to the module not expressly authorised by the manufacturer will result in a loss of any liability claims to Jetter AG.

The original parts are specially designed for the JX2-OD8 module. Parts and equipment of other manufacturers are not tested on our part, and are, therefore, not released by us. The installation of such parts may impair the safety and the proper functioning of the JX2-OD8 module.

For any damages resulting from the use of non original parts and equipment any claims with respect to liability of Jetter AG are excluded.

Malfunctions

- Malfunctions or other damages are to be reported to an authorised person immediately.
- Safeguard the JX2-OD8 module against misuse or accidental use.
- Only qualified experts are allowed to carry out repairs.

Information Signs and Labels

- Writings, information signs, and labels always have to be observed and kept readable.
- Damaged or unreadable information signs and labels are to be exchanged.

1.2 Instructions on EMI

The noise immunity of a system corresponds to the weakest component of the system. For this reason, correct wiring and shielding of the cables is important.



Important!

Measures for increasing immunity to interference:

- On principle, physical separation should be maintained between signal and voltage lines.
- Shield both sides of the cable.
- The entire shield must be drawn behind the isolation, and then be clamped under an earthed strain relief with the greatest possible surface area.

When male connectors are used:

- Only use metallised connectors, e.g. SUB-D with metallised housing. Please take care of direct connection of the strain relief with the housing here as well (refer to Fig. 1).

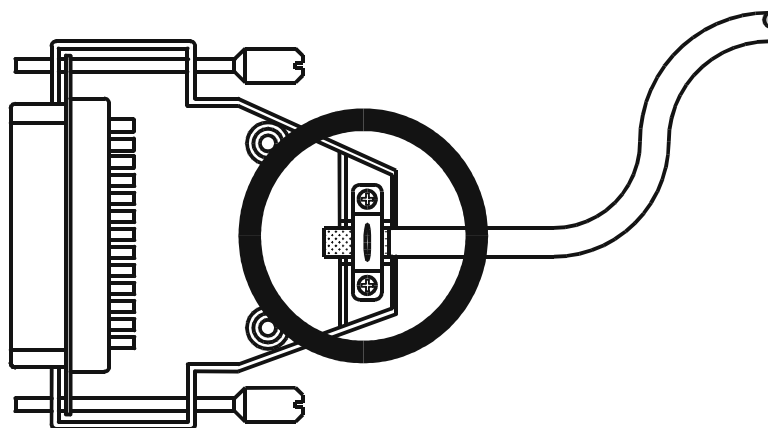

Fig. 1: Shielding of SUB-D connectors in conformity with the EMC standards.

2 Physical Dimensions

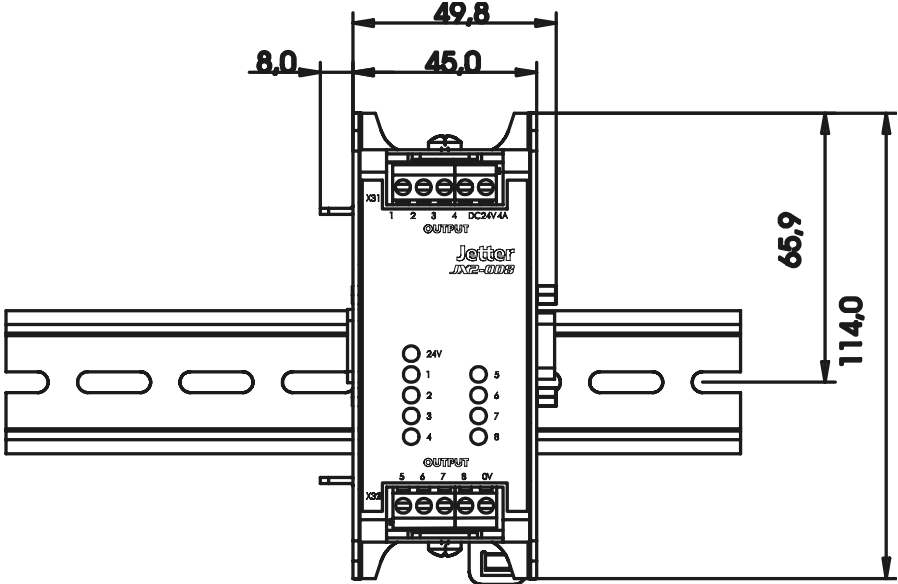

Fig. 2: Front View - JX2-OD8

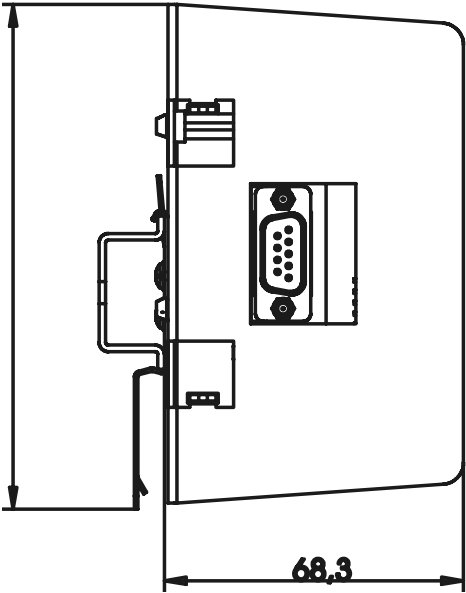

Fig. 3: Side View - JX2-OD8

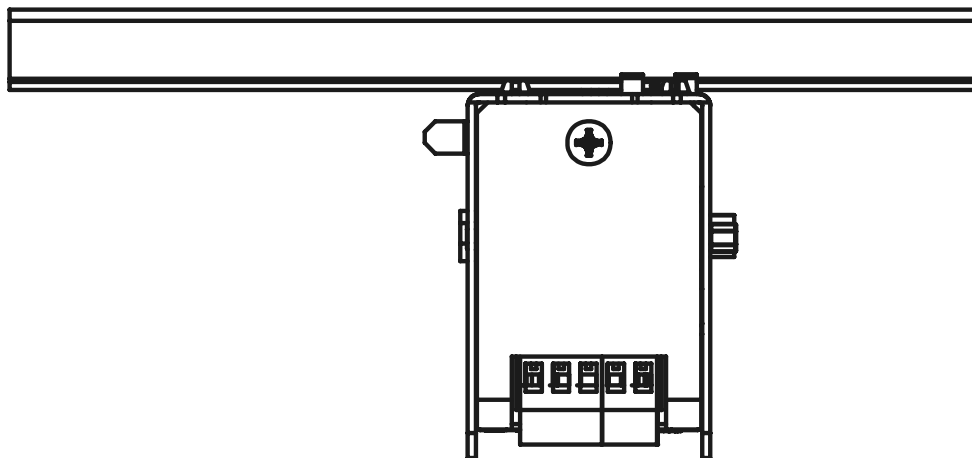

Fig. 4: Top View - JX2-OD8

3 Operating Parameters

Environmental Operating Parameters		
Parameter	Value	Reference
Operating Temperature Range	0 °C through 50 °C	
Storage Temperature Range	-25 °C through +70 °C	DIN EN 61131-2 DIN EN 60068-2-1 DIN EN 60068-2-2
Air Humidity / Humidity Rating	5 % to 95 % No condensing	DIN EN 61131-2
Pollution Degree	2	DIN EN 61131-2
Corrosion Immunity/ Chemical Resistance	No special protection against corrosion. Ambient air must be free from higher concentrations of acids, alkaline solutions, corrosive agents, salts, metal vapours, or other corrosive or electroconductive contaminants.	
Operating Altitude	Up to 2000 m above sea level	DIN EN 61131-2

Mechanical Operating Parameters		
Parameter	Value	Reference
Free Falls Withstanding Test	Height of fall (units within packing): 1 m	DIN EN 61131-2 DIN EN 60068-2-32
Vibration Resistance	10 Hz - 57 Hz: with an amplitude of 0.0375 mm for continuous operation (peak amplitude of 0.075 mm) 57 Hz -150 Hz: 0.5 g constant acceleration for continuous operation (1 g constant acceleration as peak value), 1 octave per minute, 10 frequency sweeps (sinusoidal), all spatial axes	DIN EN 61131-2 IEC 68-2-6
Shock Resistance	15 g occasionally, 11 ms, sinusoidal half-wave, 2 shocks in all three spatial axes	DIN EN 61131-2 IEC 68-2-27
Degree of Protection	IP20, rear: IP10	DIN EN 60529
Mounting Position	Any position, snapped on DIN Rail	

Operating Parameters - Electrical Safety		
Parameter	Value	Reference
Class of Protection	III	DIN EN 61131-2
Dielectric Test Voltage	Functional ground is connected to chassis ground internally.	DIN EN 61131-2
Overvoltage Category	II	DIN EN 61131-2

Operating Parameters (EMC) - Emitted Interference		
Parameter	Value	Reference
Enclosure	Frequency 30 -230 MHz, limit 30 dB ($\mu\text{V}/\text{m}$) at 10 m distance frequency band 230-1000 MHz, limit 37 dB ($\mu\text{V}/\text{m}$) at 10 m distance (class B)	DIN EN 50081-1 DIN EN 55011 DIN EN 50081-2

Operating Parameters (EMC) - Immunity to Interference of Housing		
Parameter	Value	Reference
Magnetic Field with Mains Frequency	50 Hz, 60 Hz 30 A/m	DIN EN 61000-6-2 DIN EN 61000-4-8
RF Field, amplitude-modulated	Frequency band 27 - 1000 MHz Test field strength 10 V/m AM 80 % with 1 kHz Criterion A	DIN EN 61131-2 DIN EN 61000-6-2 DIN EN 61000-4-3
ESD	Discharge through air: Test peak voltage 15 kV (Humidity Rating RH-2 / ESD-4) Contact Discharge: Test peak voltage 4 kV (severity level 2) Criterion A	DIN EN 61000-6-2 DIN EN 61131-2 DIN EN 61000-4-2

Operating Parameters (EMC) - Immunity to Interference of Signal Ports		
Parameter	Value	Reference
Asymmetric RF, amplitude-modulated	Frequency band 0.15 -80 MHz Test voltage 10 V AM 80 % with 1 kHz Source impedance 150 Ohm Criterion A	DIN EN 61000-6-2 DIN EN 61000-4-6
Burst	Test voltage 1 kV tr/tn 5/50 ns Repetition rate 5 kHz Criterion A	DIN EN 61131-2 DIN EN 61000-6-2 DIN EN 61000-4-4

Operating Parameters (EMC) - Immunity to Interference of DC Power Supply In- and Outputs		
Parameter	Value	Reference
Asymmetric RF, amplitude-modulated	Frequency band 0.15 -80 MHz Test voltage 10 V AM 80 % with 1 kHz Source impedance 150 Ohm Criterion A	DIN EN 61000-6-2 DIN EN 61000-4-6
Burst	Test voltage 2 kV tr/tn 5/50 ns Repetition rate 5 kHz Criterion A	DIN EN 61131-2 DIN EN 61000-6-2 DIN EN 61000-4-4

4 Technical Data

Technical Data - JX2-OD8 Module	
8 digital outputs	DC 24 V, 0.5 A, pnp
Power supply of the internal logic circuit	<ul style="list-style-type: none"> centralised arrangement: via basic unit decentralised arrangement: via power supply module JX2-PS1.
Connection to the basic unit via system bus	Male connector SUB-D, 9 pins
Output terminals	Plug-in terminal blocks
LEDs, outputs 1 -8	Output is set on DC 24 V; pick-off method: Hardware signal
Enclosure	Aluminium, painted
Dimensions (H x W x D in mm)	115 x 45 x 69
Weight	350 g
Mounting	DIN Rail
Heat loss of logic circuit	0.3 W
Type of outputs	Transistor, pnp
Rated voltage	DC 24 V -15 % .. +20 %
Voltage Range	DC 20 .. 30 V
Load current	max. 0.5 A per output
Output power of outputs	96 W
Electrical Isolation	None
Protective circuit	Short circuit, overvoltage, overtemperature
Protection against inductive loads	yes
Principle of Operation	Non-latching
Signal voltage ON	typ. $V_{\text{Supply}} - 1.5 \text{ V}$

**Caution**

Make sure that digital output modules are disconnected from the supply before inserting or removing them. When removing or inserting the module, the supply lines as well as the signal lines must be de-energised. Otherwise the JX2-OD8 module will be destroyed.

**Note!**

A digital output may directly (without additional load) be connected to a digital input.

5 JX2-OD8 - Digital Output Module

The JX2-OD8 module is for connecting centralised or decentralised equipment, such as actuators, valves or contactors.

5.1 Description of Connections

On the expansion module, 8 terminals have been provided for 24 V output signals. The 0 V signal is to be connected to the 0 V terminal of the electric cabinet.

Terminal Specifications

- 5-pole terminal block COMBICON RM 5.08 (for printed circuit boards)
- Cable cross-sectional area: 0.25 - 2.5 mm²
- Torque (for input plug screws): 0.5 .. 0.6 Nm
- The maximum stripping length for input lines is 7 mm
- The accepted VDE guidelines have to be observed
- Flat-bladed screwdriver: 0.6 x 3.5 x 100 mm

Connecting Cable Specifications

- Not required

Cable Shielding

- Not required

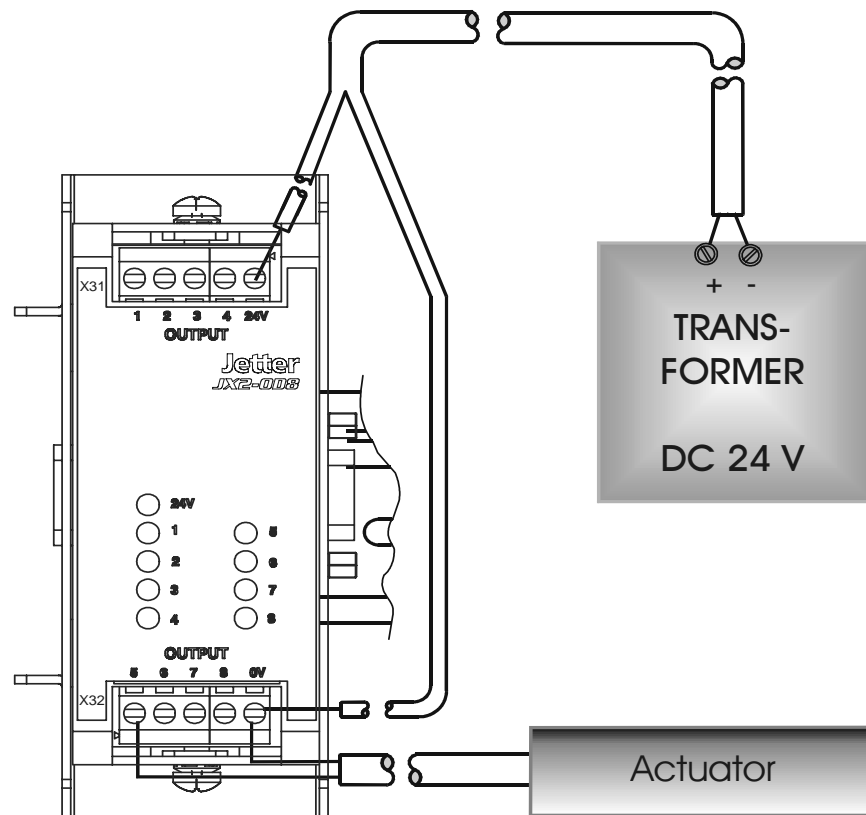

Fig. 5: Example: Output Wiring of a JX2-OD8 Module

5.2 Description of LEDs

The LEDs show that a 24 V output signal is applied to the corresponding output.

6 Access to Variables, Inputs and Outputs

The register address is made up of the module number and the respective input number:

Coding of Input Numbers: xyz

Meaning:

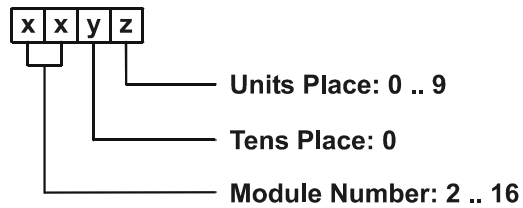

Note!

Digital input or output modules are taken into account when assigning module numbers. Intelligent modules, such as SV, SM, PID, etc., located among the digital input and output modules, are not taken into account.

Module no. 1 is assigned to the basic control unit. Starting from there, the module numbers are counted left to right.

Example 1:

The table below shows the input/output numbering for a basic controller with two JX2-ID 8 modules and one JX2-OD 8 output module, arranged as follows:

JetControl Basic Controller	JX2-OD8 Output Module	JX2-ID8 Input Module	JX2-ID8 Input Module
Module # 1	Module # 2	Module # 3	Module # 4
Inputs and Outputs 101 .. 108	Output 201 .. 208	Input 301 .. 308	Input 401 .. 408

Example 2:

Basic controller with one intelligent expansion module JX2-SV1, one digital input module JX2-ID8, and one digital output module JX2-OD8.

JetControl Basic Controller	JX2-OD8 Output Module	JX2-SV1 Servo Module	JX2-ID8 Input Module
Module # 1	Module # 2	Module # 3	Module # 4
Inputs and Outputs 101 .. 108	Output 201 .. 208	SV-Module	!!! Input 301 .. 308

**Note!**

From example 2 can be seen that module JX2-SV1 is not taken into account when numbering digital inputs and outputs.